

# GREYSTONE ENERGY SYSTEMS INC

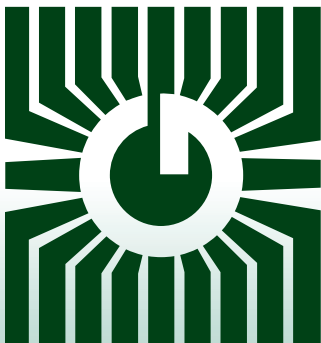

## DUCT SMOKE DETECTOR Model SL2000

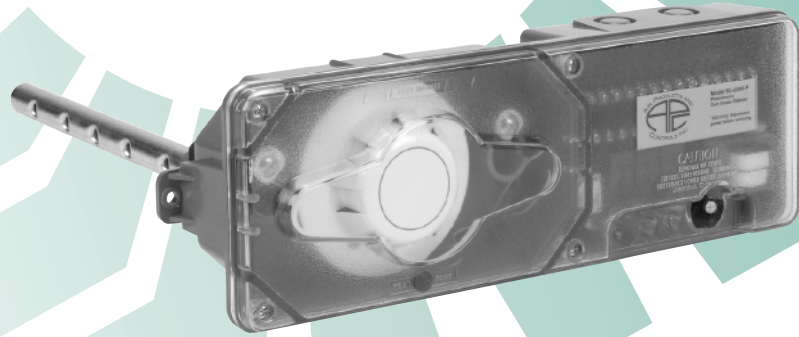

### Precision duct smoke detection

#### FEATURES:

- 24 VAC/DC or 120/240 VAC operation
- Simple change-out of photo or ion detector heads
- Low flow air velocity rating from 100 to 4000 FPM
- UL, CSFM and MEA Listed
- Two (2) sets of 10A form "C" alarm contacts
- One (1) set of 10A form "C" trouble contacts
- Easy and quick mounting to round or rectangular ducts from 1' - 12' wide
- Clear cover for convenient visual inspection
- Built-in reset switch that is also an alarm test switch

*Peace of mind  
through reliable  
smoke detectors*

GREYSTONE HAS AN ISO 9001 REGISTERED QUALITY SYSTEM

## PRODUCT APPLICATION / DESCRIPTION:

The SL-2000 Series Smoke Detector is the latest innovation for early detection of smoke and products of combustion present in air moving through HVAC ducts in Commercial, Industrial and Residential application. The SL-2000 Series, 4-wire duct housing will accommodate either the ionization sensor or the photoelectric sensor. The interchangeable detector heads allow easy removal for quick cleaning and maintenance, or a change in application without removing the duct housing. The SL-2000 samples air currents passing through a duct and gives dependable performance for management of fans, blowers, and air conditioning systems.

## WIRING:

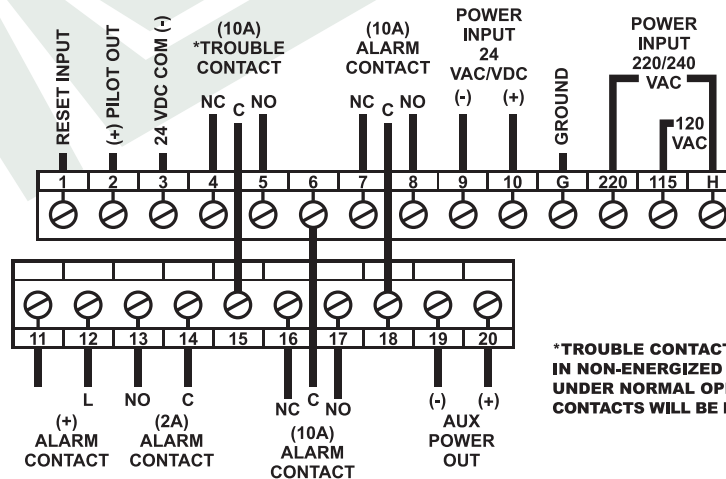

Output terminals are provided for remote accessories such as horns, strobes, remote status indicators and test/reset key switches or push buttons.

The SL-2000 includes many features that represent true innovations from current generation duct smoke detectors. It is designed and built to meet all local requirements, as well as the NFPA regarding duct smoke detectors.

All detectors must be used with a metal sampling tube, model STN series.

## PRODUCT SPECIFICATIONS:

Models SL-2000-N and SL-2000-P	
<b>Power Requirements</b>	Stand By: 230 VAC-7.9 mA 115 VAC-13.8 mA 24 VAC-39.4 mA 24 VDC-13.5 mA  Alarm Current: 230 VAC-16.0 mA 115 VAC-27.0 mA 24 VAC-59.3 mA 24 VDC-128.7 mA
<b>Relay Contact Rating</b>	Alarm Contacts: 2 sets form "C" rated at 10 amps @115 VAC resistive 1 set form "A" rated at 2 amps Trouble Contacts: 1 set form "C" rated at 10 amps @ 115 VAC resistive
<b>Air Velocity</b>	.50 to 20 M/S (100 to 4000 FPM)
<b>Ambient Temperature</b>	SL-2000-N 0 to 70°C (32 to 158°F) SL-2000-P 0 to 60°C (32 to 140°F)
<b>Humidity</b>	10% to 85% R.H. No Condensation
<b>Wiring</b>	#14 to #22 AWG
<b>Approvals</b>	Underwriters Laboratories Listed: (UL268A;UROX.S2829) CSFM Listed: (3240-1004:105) MEA Listed: (73-92E;VOL.27)
<b>Material</b>	Grey plastic backbox, clear plastic cover
<b>Dimensions</b>	343 mm L x 115 mm H x 58 mm D (13.5" x 4.5" x 2.25")
<b>Max. Net Wt.</b>	1.14 KG (2.5 lbs.)
<b>Manufacturer</b>	Built for Greystone by Air Products and Controls, Inc.

## ORDERING INFORMATION:

Part No.	Description
SL-2000-N	4-wire ionization duct detector, high temperature applications
SL-2000-P	4-wire photoelectric duct detector

## ACCESSORIES

Part No.	Description
STN-1.0	Metal sampling tube duct widths 1' - 2'
STN-2.5	Metal sampling tube duct widths 2' - 4'
STN-5.0	Metal sampling tube duct widths 4' - 8'
STN-10.0	Metal sampling tube duct widths 8' - 12'
MS-RA/R	Remote Alarm LED (Red) and Push-Button Test/Reset Switch
MS-KA/R	Remote Alarm LED (Red) and Key-Operated Test/Reset Switch
MS-RH/KA/P/R	Remote Alarm Horn, Alarm LED (Red), Pilot LED (Green) and Key-Operated Test/Reset Switch



CSFM LISTED



Greystone Energy Systems Inc. is one of North America's largest ISO registered manufacturers of HVAC sensors and transducers for Building Automation Management Systems.

We have conscientiously established a worldwide reputation as an industry leader by maintaining leading-edge design technology, prompt technical support, and a commitment to on-time deliveries. We take pride in our Quality Management System which is ISO 9001 certified, assuring our customers of consistent product reliability.



150 English Drive, Moncton, NB Canada E1E 4G7  
Tel.: (506) 853-3057 North America: 1-800-561-5611  
e-mail: mail@greystoneenergy.com

Fax: (506) 853-6014  
web site: www.greystoneenergy.com