

GREYSTONE ENERGY SYSTEMS INC

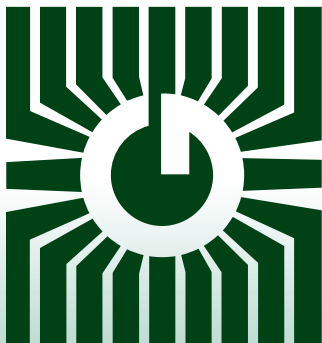

AIR FLOW TRANSDUCER ESF-35-2

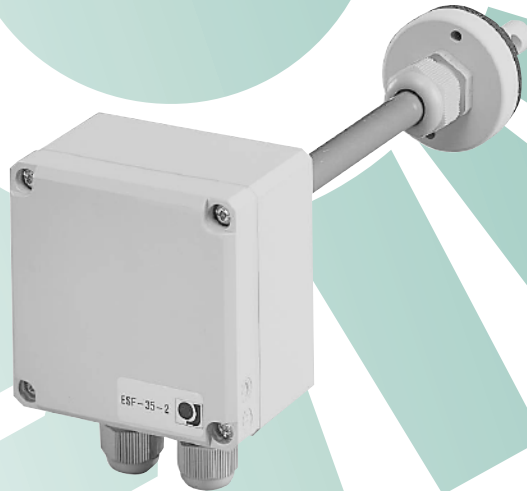

Precision airflow control/sensing

FEATURES:

- Converts airspeed into a 4 - 20mA or a 0 - 10 VDC signal
- Linear output signal
- Made with corrosion resistant material
- Fully electronic registration of airflow speed
- AC or DC voltage supply
- Compensates for changes of air temperature
- Telescopic sensor facilitates installation
- Temperature output signal 0 - 10 VDC
- Fuse protected

*Peace of mind
through reliable
air velocity monitoring*

GREYSTONE HAS AN ISO 9001 REGISTERED QUALITY SYSTEM

APPLICATION:

The ESF-35-2 airflow transducer can be used in a wide range of applications such as:

- Measurements of airflow speed via PLC/outstation/EMS
- Regulation of airflow speed
- Monitoring of airflow speed

FUNCTION:

The ESF-35-2 transducer registers the airflow speed according to a thermal principle based on the fact that the cooling action of air increases with airspeed. The action is measured and converted to a 4 - 20 mA or a 0 - 10 V signal corresponding to airflow speeds from 0 - 8 m/s (0 - 1575 ft/min) or 0 - 16 m/s (0 - 3150 ft/min).

TECHNICAL DATA:

Airflow speed	0 - 16 m/s (3150 ft/min),
(jumper selectable)	0 - 8 m/s (1575 ft/min)
Output signal (flow)	4 - 20mA, 0 - 10 VDC
Output signal (temperature)	0 - 10 VDC
Temperature range	0 - 50°C (32°F - 122°F)
Air temperature	-10°C - 60°C (14°F - 140°F)
Ambient temperature	-20°C - 50°C (-4°F - 122°F)
AC voltage supply	24 VAC (120mA)
DC voltage supply	16 - 30 VDC (80mA)
Absolute accuracy	±5 %
Rise time	20 sec
Time constant	5 sec
Depth of insertion in channel	50 - 200 mm (2 - 8 in.)
Dimensions (H x W x D)	80 x 80 x 55 mm
	(3.15 x 3.15 x 2.17 in.)

INSTALLATION:

The airflow transducer ESF-35-2 is installed in such a way that the current of air passes through the gap of the sensor head. Conductors to and from the transducer should be kept isolated from high-power conductors where powerful transient voltage spikes may appear.

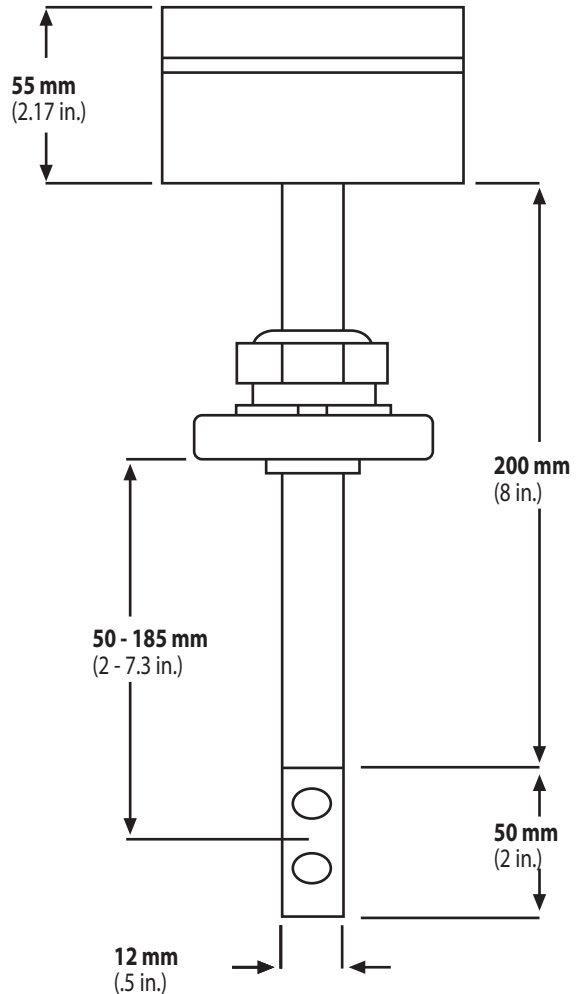
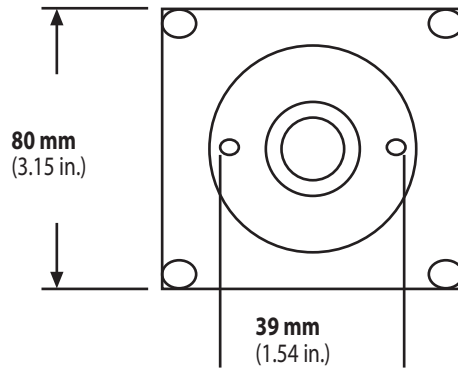
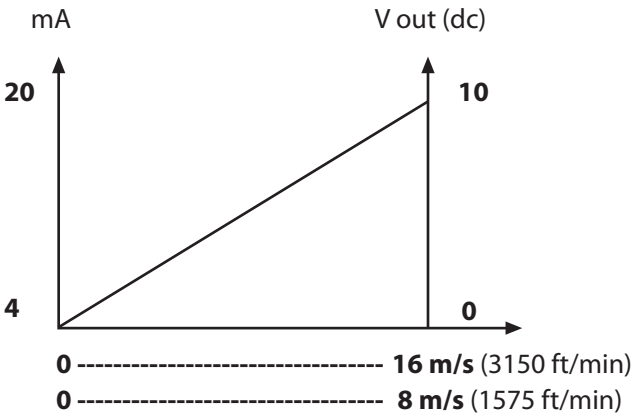

GREYSTONE

ENERGY SYSTEMS INC

Greystone Energy Systems, Inc.
150 English Drive, Moncton, NB
Canada E1E 4G7

(506) 853-3057 Fax: (506) 853-6014
North America: 1-800-561-5611
e-mail: mail@greystoneenergy.com
www.greystoneenergy.com



Greystone Energy Systems Inc. is one of North America's largest ISO registered manufacturers of HVAC sensors and transducers for Building Automation Management Systems.

We have conscientiously established a worldwide reputation as an industry leader by maintaining leading-edge design technology, prompt technical support, and a commitment to on-time deliveries. We take pride in our Quality Management System which is ISO 9001 certified, assuring our customers of consistent product reliability.