

General

The VP512A is a normally-open, single seated, straight-through or angle globe valve for proportional control of either steam or hot water in unit ventilators.

Features

- Equal percentage, high lift throttling guide providing accurate control over wide load variations.
- Molded, replaceable composition disc for tight shut-off.
- Replaceable brass seat.
- Self-adjusting, spring-loaded Teflon packing.
- Back-seating arrangement to allow repacking without shutting down or draining system.
- Rotatable operator for aligning air connection with control air piping.
- Integral union connection to simplify installation and service.

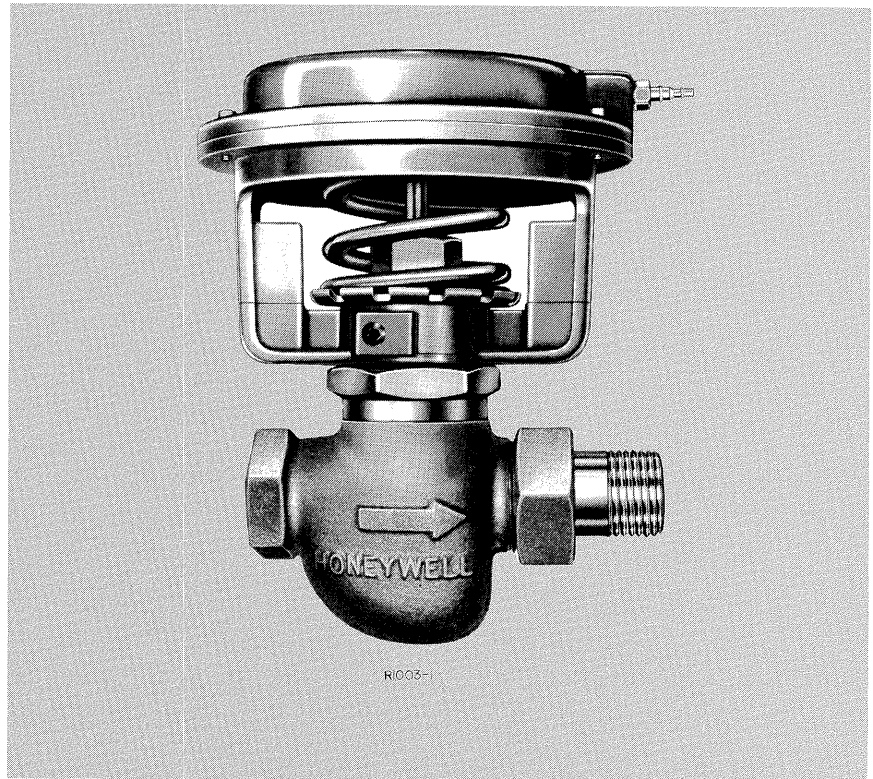

Specifications

DIMENSIONS

Refer to Fig. 1 and Table 1.

BODY

NOMINAL BODY RATING

150 lb/in² (1034 kPa).

VALVE RATINGS

See Table 2.

CLOSE-OFF RATINGS

See Fig. 2.

CONNECTIONS

Inlet: Female NPT.

Outlet: Male union.

OPERATOR

DIAPHRAGM

Molded neoprene.

CONTROL AIR PRESSURE

25 lb/in² (172 kPa) maximum.

AIR CONNECTIONS

Combination barbed fitting for 5/32 and 1/4 in. (4 and 6 mm) plastic tubing.

OPERATING RANGE (Nonadjustable)

3 to 8 lb/in² (21 to 55 kPa).

6 to 11 lb/in² (41 to 76 kPa).

AMBIENT TEMPERATURE

160 F (71 C) maximum.

WHEN ORDERING, SPECIFY

Model Number

Nominal pipe size

Flow Coefficient (Cv)

Angle or straight through type

Spring range

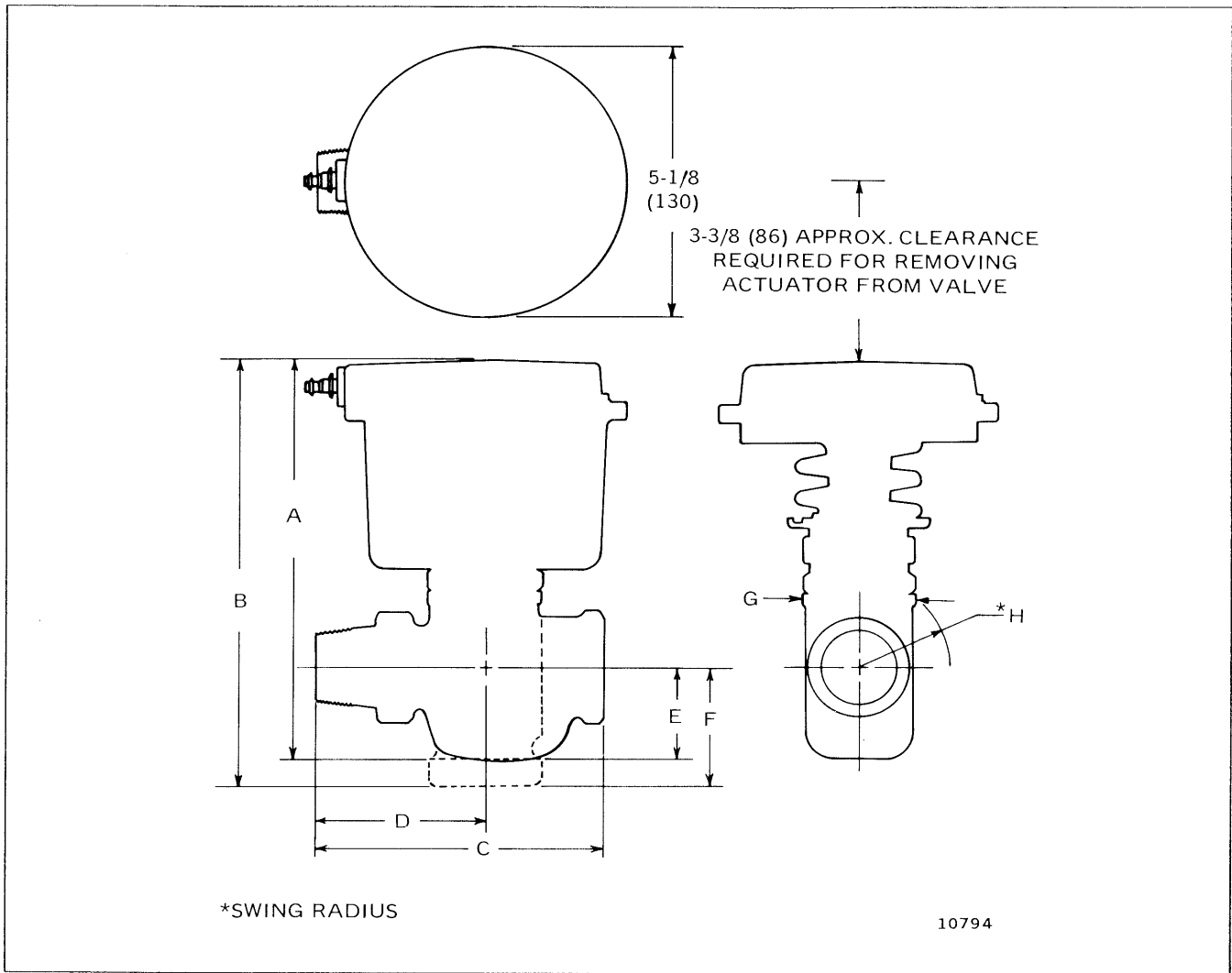

FIG. 1. VP512A APPROXIMATE DIMENSIONS IN INCHES (MILLIMETERS). REFER TO TABLE 1 FOR DIMENSIONS.

Table 1. VP512A Approximate Dimensions in Inches (Millimeters). Refer to Fig. 1.

Valve Size	Body Type	A	B	C	D	E	F	G	H	
1/2 in.	Straight	6-31/32 (177)	-----	4-1/2 (114)	2-5/8 (67)	1-3/4 (44)	-----	1-13/16 (46)	1-9/16 (40)	
	Angle	-----	7-7/32 (183)	-----	2-5/8 (67)	-----	2 (51)		-----	
3/4 in.	Straight	6-31/32 (177)	-----	4-7/8 (124)	2-7/8 (73)	1-3/4 (44)	-----		1-31/32 (50)	1-9/16 (40)
	Angle	-----	7-11/32 (187)	-----	2-7/8 (73)	-----	2-1/8 (54)			-----
1 in.	Straight	6-31/32 (177)	-----	5-3/8 (137)	3-1/8 (79)	1-5/8 (41)	-----	2-9/16 (65)	1-23/32 (44)	
	Angle	-----	7-15/32 (190)	-----	3-1/8 (79)	-----	2-1/8 (54)		-----	
1-1/4 in.	Straight	7-1/32 (179)	-----	6-1/4 (159)	3-3/4 (95)	1-1/2 (38)	-----	-----	2-1/32 (52)	
	Angle	-----	7-21/32 (195)	-----	3-3/4 (95)	-----	2-1/8 (54)		-----	

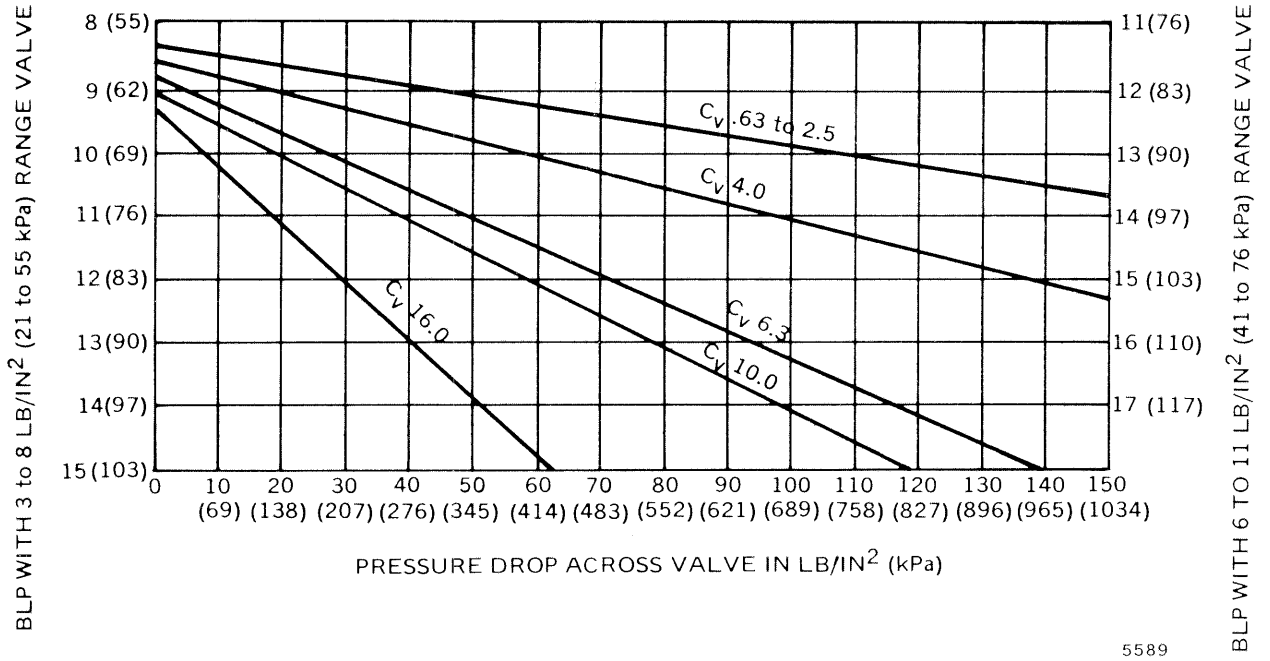

FIG. 2. CLOSE-OFF RATINGS AT VARIOUS BRANCH LINE PRESSURES.

Table 2. Valve Ratings.

Pipe Size in Inches (mm)	Cv	Recommended Max. Pressure, lb/in ² (kPa), Differential for Normal Life of Disc and Seat				Packing or Body Limitation				Normal Limiting Factor
		Two-Position		Proportional		Max. Temperature of Agent, F (C)		Max. Pressure of Agent, lb/in ² (kPa)		
		Steam	Water	Steam	Water	Steam	Water**	Steam	Water	
		Steam	Water	Steam	Water	Steam	Water**	Steam	Water	
1/2 in.	0.63	50 (345)	75 (515)	25 (175)	35 (240)	337 (169)	240 (115)	100 (685)	100 (685)	Disc or close-off
	1.0									
	1.6									
	2.5									
3/4 in.	4.0	50 (345)	75 (515)	25 (175)	35 (240)	337 (169)	240 (115)	100 (685)	100 (685)	Disc or close-off
	6.3									
1 in.	10.0	50 (345)	75 (515)	25 (175)	35 (240)	337 (169)	240 (115)	100 (685)	100 (685)	Disc or close-off
1-1/4 in.	16.0									

**Minimum water temperature, 40 F (4 C). Maximum temperature differential when used with alternating hot and cold water, 140 F (60 C).

Typical Operation

An increase in control air pressure moves the valve stem toward the closed position, reducing flow through the valve (Fig. 3).

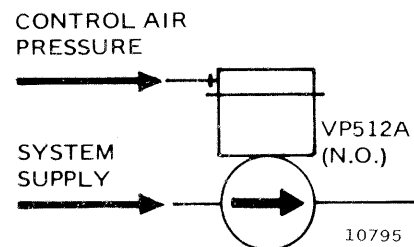

FIG. 3. VP512A TYPICAL OPERATION.