

RP971A Ratio Relay

SPECIFICATION DATA

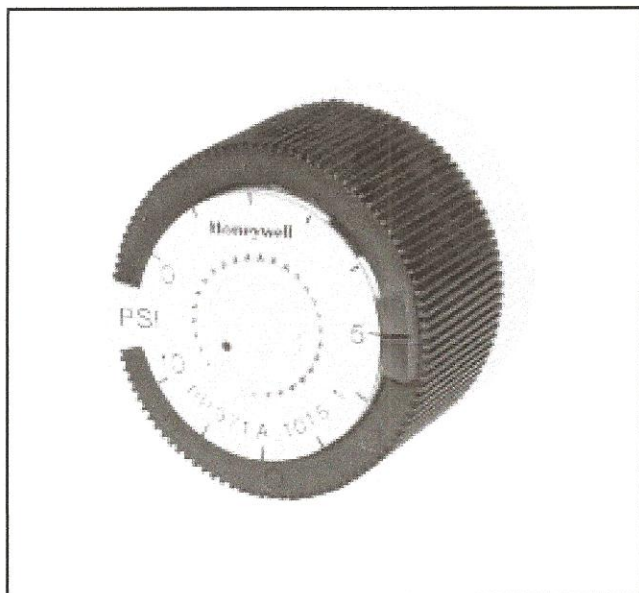

FEATURES

- Adjustable pilot start point pressures
- Two pilot pressure spans available
- Four sharp barb air connections
- Molded plastic construction with neoprene diaphragms and stainless steel valve seats
- 100 mesh stainless steel screens in main and branch ports
- Designed for in-line mounting but can be wall or panel mounted

GENERAL

The RP971A Ratio Relay is a four port nonbleed pneumatic relay which produces a modulating pressure output proportional to pilot input changes. It is used to control pneumatic valve or damper actuators in sequence from a single thermostat.

EPRI Edgemont Precision Rebuilders, Inc
Matlack Industrial Center
207 Carter Dr Unit C
West Chester, PA 19382
800-356-3774



DESCRIPTION

The RP971A Ratio Relay is a four port nonbleed pneumatic relay which produces a modulating pressure output proportional to pilot input changes. It is used to control pneumatic valve or damper actuators in sequence from a single thermostat.

SPECIFICATIONS

Model:

RP971A Ratio Relay

Operating Range:

0 to 18 psi (0 to 124 kPa)

Maximum Safe Air Pressure:

30 psi (205 kPa)

Ambient Operating Limits:

Temperature: 0 to 140F (-18 to 60C)

Humidity: 5 to 95%

Operating Air Pressures:

Pilot: 3 to 15 psi (21 to 103 kPa)

Main: 18 psi (124 kPa)

Air Handling Capacity:

0.039 scfm at 1 psi differential (18 ml/s at 5 kPa differential)

Air Consumption:

0.002 scfm (0.8 ml/s) maximum

Start Point:

Adjustable from 0 to 10 psi (0 to 69 kPa)

Pilot Operating Span:

3 or 5 psi (20 or 35 kPa), nonadjustable

Mounting:

In line, wall, or panel mounted

Air Connections:

Barb type for 1/4-in. (6-mm) O.D. plastic tubing for Port 1 and 5/32-in. (4-mm) O.D. plastic tubing for Ports 2, 3, and 4

Construction:

Molded plastic with neoprene diaphragm, stainless steel valve seats, and 100-mesh stainless steel filters in main and branch ports

Accessories:

801629T Cable Clamp (2 in. [51 mm] dia) for wall mounting if desired

Dimensions:

2 in. (51 mm) dia x 2-5/8 (67 mm) deep

Home and Building Control

Honeywell Inc.
Honeywell Plaza
P.O. Box 524
Minneapolis MN 55408-0524

Honeywell Latin American Division

Miami Lakes Headquarters
14505 Commerce Way Suite 500
Miami Lakes FL 33016

Home and Building Control

Honeywell Limited-Honeywell Limitée
155 Gordon Baker Road
North York, Ontario
M2H 2C9

Honeywell Europe S.A.

3 Avenue du Bourget
B-1140 Brussels Belgium

Honeywell Asia Pacific Inc.

Room 3213-3225
Sun Hung Kai Centre
No. 30 Harbour Road
Wanchai
Hong Kong

EPRI Edgemont Precision Rebuilders, Inc
Matlack Industrial Center
207 Carter Dr Unit C
West Chester, PA 19382
800-356-3774



RP971A Pneumatic Ratio (Sequencing) Relay

INSTALLATION INSTRUCTIONS

DESCRIPTION

The RP971A Ratio Relay is a nonbleed, pneumatic relay that produces a modulating pressure output in proportion to pilot pressure input changes, and is suitable for use in all types of pneumatic control systems. In a typical application, two or three relays are used to control pneumatic valve or damper actuators in sequence from a single signal source.

Fig. 1 shows approximate dimensions in inches (millimeters).

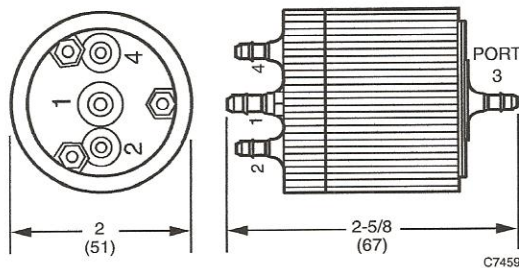

Fig. 1. RP971A Dimensions,

INSTALLATION

Mounting

Suspend on tubing or mount on a surface (see Fig. 2).

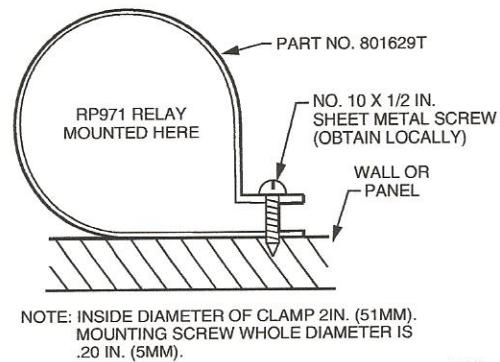

Fig. 2. Typical Surface Mounting.

Piping

Fig. 3 shows adaptation piping. Port 1 (Main, Supply) sharp barb for 1/4-in. (6 mm) O.D. tubing. Ports 2, 3, and 4 (Branch, Output; Pilot, Input; and Exhaust, respectively), sharp barb for 5/32-in (4 mm) O.D. tubing.

CAUTION

To prevent damage to the sharp barb connections, do not attempt to cut or pull tubing. To remove the tubing from the barb connections, cut tubing a few inches from the control device. Use a coupling to reconnect tubing.

NOTE: If the system is other than copper or polyethylene tubing, adapt as shown in Fig. 3. Some models provide parts for adapting.

EPRI Edgemont Precision Rebuilders, Inc
Matlack Industrial Center
207 Carter Dr Unit C
West Chester, PA 19382
800-356-3774



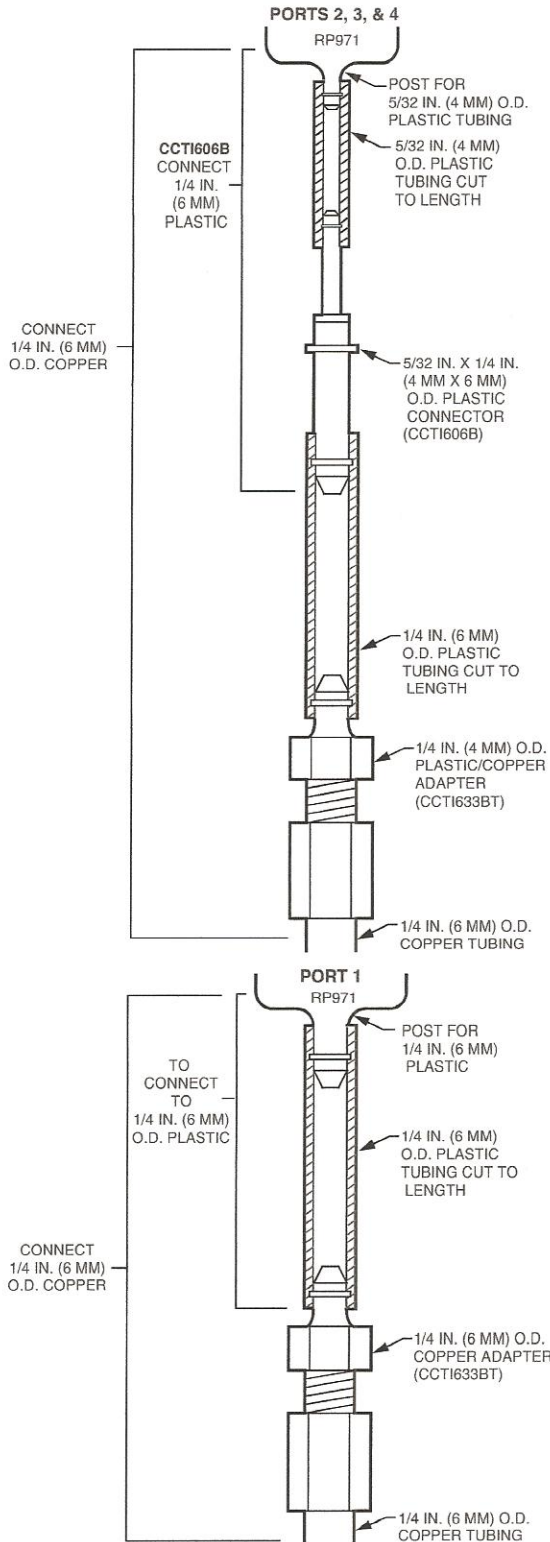

NOTE: PORT 4 IS TYPICALLY NOT CONNECTED

CB249

Fig. 3. Adaptation Piping.

Port Identification Table

The shaded area of the following table identifies the ports on older Honeywell pneumatic relays when upgrading installation.

	RP971A	RP907
Main	1	M
Pilot	3	P
Branch	2	B
Exhaust	4	—

Adjustments

The pilot start point pressures are continuously adjustable from 0 to 10 psi (0 to 69 kPa.)

Checkout and Test

Verify that the RP971A performs according to the following equation:

$$\text{Output} = \left(\frac{10}{\text{Span}} \times (\text{Pilot} - \text{Pilot Start Point}) \right) + 3$$

EXAMPLE 1:

Span = 3 psi
Pilot Startpoint = 6 psi

$$\text{Output} = \left(\frac{10}{3} \times (\text{Pilot} - 6) \right) + 3$$

Pilot (psi)	Output (psi)
6	3
7.5	8
9	13

EXAMPLE 2:

Span = 5 psi
Pilot Startpoint = 8 psi

$$\text{Output} = \left(\frac{10}{5} \times (\text{Pilot} - 8) \right) + 3$$

Pilot (psi)	Output (psi)
8	3
10.5	13
13	8

EPRI Edgemont Precision Rebuilders, Inc
Matlack Industrial Center
207 Carter Dr Unit C
West Chester, PA 19382
800-356-3774

ENGINEERING DATA

Specifications

Model:

- RP971A Pneumatic Ratio (Sequencing) Relay
- 3 psi (21 kPa) pilot span
- 5 psi (90 kPa) pilot span

Operating Pressure (Switch and Pilot) Range:

- Normal Main: 118 psi (124 kPa)
- Maximum Safe Main: 30 psi (207 kPa)
- Pilot: 0 to 18 psi (21 to 124 kPa)

Operating Limits:

- Temperature: 0 to 140°F (-18 to 60°C)
- Relative Humidity: 5 to 95%

Air Handling Capacity (Feed and Bleed):

- 0.039 scfm at ± 1.02 psi droop (18.3 ml/sec at 7 kPa droop). Conditions: 18 psi (124 kPa) Main and 9 psi (62 kPa) Pilot

Air Consumption:

- 0.002 scfm (1.0 ml/s) maximum

Start Point:

- Adjustable 0 to 10 psi (0 to 69 kPa)

Construction:

- Molded plastic with neoprene diaphragm, stainless steel valve seats, and 100-mesh stainless steel filters in main and branch ports

Operation

The effective area ratio between the pilot and feedback diaphragms controls the ratio between the pilot and branchline pressures. Fig. 4 shows a cutaway of typical operation. Exhaust Port 4 is not used. The 3 psi (21 kPa) model gives a 10 psi (69 kPa) variation in branchline pressure for a 3 psi (21 kPa) change in pressure. The start adjustment sets pilot pressure at the point where branchline pressure begins to increase above 3 psi (21 kPa.) For example, a 5 psi (34 kPa) setting outputs 3 psi (21 kPa) with a 5 psi (34 kPa) pilot signal.

Fig. 4A shows the RP971A in a balanced condition. As pilot pressure increases, the exhaust tube lifts Diaphragm 1, feeding main air into the branch chamber (Fig. 4B) through small holes in the diaphragm. This pressure pushes down on the feedback diaphragm and retracts the exhaust tube, which returns the relay to a balanced condition (Fig. 4C.) When pilot pressure drops, the exhaust tube retracts further and bleeds the branchline air into the atmosphere (Fig. 4D.) When sufficient air has bled off, the relay returns to a balanced condition with a new and lower branchline pressure (Fig. 4E.)

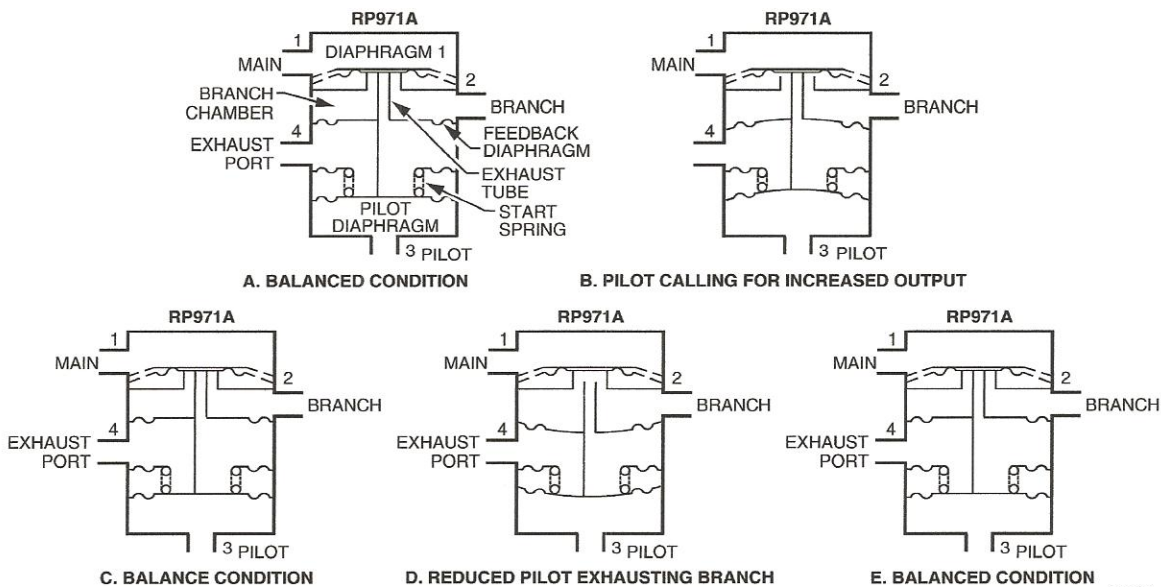

Fig. 4. Typical RP971A Operation.

EPRI Edgemont Precision Rebuilders, Inc
 Matlack Industrial Center
 207 Carter Dr Unit C
 West Chester, PA 19382
 800-356-3774

Application

Fig. 5 shows graphical examples of 3 and 5 psi (21 and 34 kPa) models.

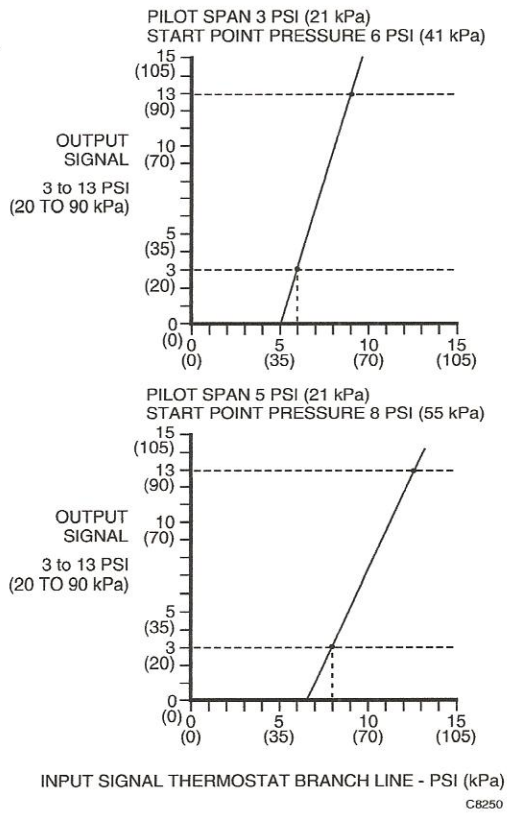

Fig. 5. Graphical Examples of 3 and 5 psi (21 and 34 kPa) models.

The RP971A is used to sequence damper actuators. Typically, it is used to sequence two to three actuators. See Fig. 6.

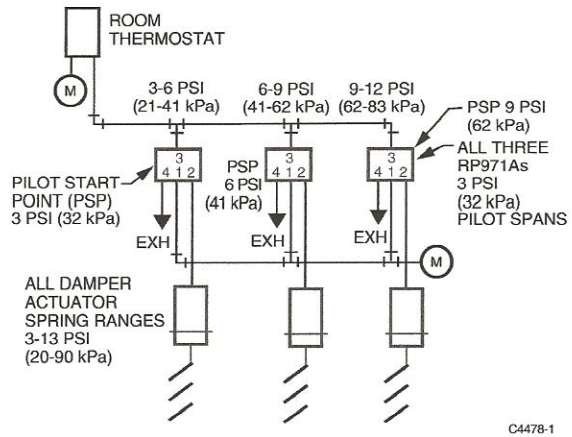

Fig. 6. Typical RP971A Application to Sequence Dampers from a Single Thermostat.

EPRI Edgemont Precision Rebuilders, Inc
Matlack Industrial Center
207 Carter Dr Unit C
West Chester, PA 19382
800-356-3774

Honeywell

Home and Building Control
Honeywell Inc.
Honeywell Plaza
P.O. Box 524
Minneapolis, MN 55408-0524

Home and Building Control
Honeywell Limited-Honeywell Limitée
155 Gordon Baker Road
North York, Ontario
M2H 2C9

Helping You Control Your World