

Powers™ Controls

D Day-Night Thermostats

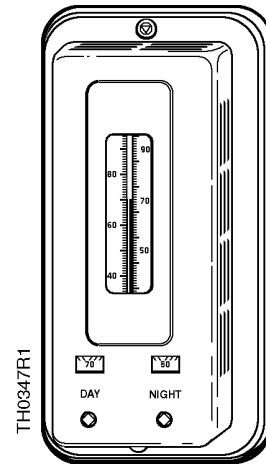

Description

The D Day-Night or Two Temperature Thermostat is available as a room-type instrument. It is essentially two thermostats incorporated into one unit: The day setting controls when the supply pressure is 18 psi (124 kPa) and the night setting controls when the supply pressure is 25 psi (172 kPa).

This thermostat is available with remote changeover of the supply air pressure. A manual reset lever is provided to allow any individual thermostat to control at its normal day setting while the balance of the system is operating on night control. Also, this manual reset lever can be moved to permit this particular thermostat to be reset to return it to night operation. When the system is changed back to day operation, all thermostats revert to automatic changeover.

Application

The D day-Night Thermostat with remote changeover is recommended for temperature control of radiation, mixing dampers or unit ventilators in schools, residences, offices and hospitals. It is particularly applicable where all rooms or offices in a zone are vacated at approximately the same time and a lower control temperature is desired at night. Changeover from day to night and vice versa (see *Operation*) can be obtained by means of a zone "day-night" selector switch or by use of a program clock. The program clock will automatically set all thermostats for day operation at a selected hour in the morning and automatically change the system to night operation at some predetermined hour in the evening.

Product Numbers

Table 1.

Product Number	Description
832-1120	Key Set Point Adjustment with Thermometer
832-1140	Concealed Set Point Adjustment with Thermometer

Specifications	Control Action	Direct Acting
	Operating Range	
	Day	60 to 80°F (15 to 26°C)
	Night	50 to 70°F (10 to 21°C)
	Operating Pressure	30 psi (206.8 kPa) Max.
	Sensitivity Fixed	2.5 psi per °F (31.0 kPa per °C)
	Temperature Response	0.5°F (0.3°C)
	Maximum Ambient Temperature	125°F (51.5°C)
	Dial Graduations (Day & Night)	2°F (1.1°C)
	Normal Air Supply Pressure	
	Day	18 psi (124.1 kPa)
	Night	25 psi (172.4 kPa)
	Dimensions	2-7/8" x 5-5/8" x 2-3/16" deep (73 mm x 143 mm x 56 mm)
	Weight	5 lbs. (2.3 kg)
	Cover Style	Key or Concealed Set Point Adjustment
Cover Finish	Silver is standard (other finishes on special order).	

Typical Specifications

All day-night thermostats shall be equipped with a volatile liquid type sensing element, shall be capable of operating on a change of plus or minus 1/2°F, (0.3°C) and shall be of the gradual type capable of positioning valves or dampers in intermediate positions. Day-night thermostats shall be of the non-bleed type so that no air shall be used except when positioning a valve or damper motor.

Day-night thermostats shall be provided with two dials: on the day cycle the range shall be adjustable from 60 to 80°F (15 to 26°C); on the night cycle from 50 to 70°F (10 to 21°C). Changeover from day temperature to night temperature shall be accomplished pneumatically by remote change of the supply pressure. A manual reset lever shall be provided to allow any individual thermostat to control at its normal day setting while the balance of the system is operating on the night setting. This reset lever must also be capable of being manually returned to night setting.

Operation

(See Figure 1)

By use of the special key furnished, the thermostat can be adjusted for desired day operation and for desired night operation. A day setting of from 60 to 80°F (15 to 26°C) or a night adjustment of 50 to 70°F (10 to 21°C) can be obtained. A thermostatic disc is attached to an adjustment lever which pivots on a pin. The action of the disc is controlled by either adjustment post or, depending on whether thermostat is operating on "day" pressure or "night" pressure.

With the adjustment lever against the adjustment post, a decrease in temperature causes the thermostatic disc to contract. This moves the control lever and the adjusting screw away from the exhaust valve assembly.

The exhaust valve opens and gradually decreases the branch return pressure from the thermostat. This decrease of control pressure opens the valve on the heating supply, or the hot blade of a mixing damper, to satisfy room temperatures.

NOTE: When the exhaust valve is open, the supply valve is held closed by the supply valve spring, so that there is no constant waste of air.

**Operation,
Continued**

With a rise in room temperature, the thermostatic disc expands forcing the control lever to close the exhaust valve assembly and open the supply valve. Branch return pressure then increases to throttle the heat supply.

The air supply port also connects the supply valve chamber to the piston plate diaphragm chamber which acts on the piston plate. When the supply pressure is raised from the day setting of 18 psi (124 kPa) to the night setting of 25 psi, (172 kPa), the piston plate forces the piston plate extension against the adjustment lever. The adjustment lever then pivots and operates from the night adjustment post. Operation on the night setting and day setting is the same except for a different control point.

Field Calibration**Day setting - System
supply pressure 18 psi
(124 kPa)**

1. Check the day air pressure reducing valve to be sure it is maintaining an 18 psi day pressure.
 2. With actual room temperature within 5°F (2.7°C) plus or minus of set point of thermostat, the cover should be removed using the special key enclosed in the thermostat kit.
 3. Loosen test screw one complete turn and immediately slip on the rubber tubing of the test gauge assembly.
 4. Adjust the day dial to the actual room temperature. The test gauge should then read 7-1/2 psi (51.7 kPa) plus or minus 1-1/2 psi (10.3 kPa). If this is not the case, turn the adjusting post in either direction until it does read approximately 7-1/2 psi (51.7 kPa). Loosen the day dial retaining screw and reset the day temperature dial to the correct room temperature. Retighten dial retainer screw being careful not to change the setting of adjustment post. Be careful not to come in contact with thermostatic disc. Wait several minutes after installing test gauge hose before actually making recalibration.
 5. Breathe onto the thermostatic disc and note whether branch pressure increases. If there is no rise in branch pressure, the thermostat is not functioning and should be returned to the factory for replacement.
-

**Night Setting - System
Pressure 25 psi
(172 kPa)**

6. Check night air pressure reducing valve to be sure system has 25 psi (172 kPa) air pressure. Room temperature should be within 5°F (2.7°C) plus or minus of the normal night temperature setting of the thermostat.
 7. Check adjustment as outlined in Step 4 and reset dial if necessary.
-

**Manual Reset - System
on 25 psi (172 kPa) Night
Operation**

8. Set manual reset lever to the right until a "click" is felt. The thermostat is now controlling at the day dial setting.
9. Return system supply pressure to day 18 psi (124 kPa). The manual reset lever should automatically return to the left hand side of day cycle.
10. If the manual reset lever does not return to the left hand side when the supply pressure is 18 psi (124 kPa), the tension of spring will have to be increased by turning the adjustment spring retainer clockwise. About one complete turn of the adjustment spring retainer clockwise will increase the pressure change about 1 psi (7 kPa).

For example: If the manual reset lever is returned to the day setting at 17-1/2 psi (120.6 kPa) system pressure, then the spring tension should be increased so that it would switch over at about 18-1/4 psi (125.7 kPa). This would be approximately three-fourths of a complete turn of the adjustment spring retainer.

Manual Reset - System on 25 psi (172 kPa) Night Operation, Continued

11. Apply 25 psi (172 kPa) night supply pressure. Move reset lever to right. Thermostat will now control at day dial setting. Check calibration.
12. Move reset lever back to left. Thermostat will now control at night dial setting. Check calibration.
13. Instrument can now be considered in calibration. Test hose should be removed and test plug screwed in tightly. Replace cover with two cover screws.

Bench Calibration

General

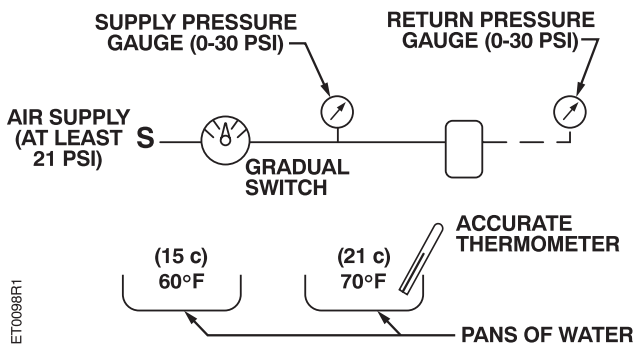

Figure 1. Test Equipment.

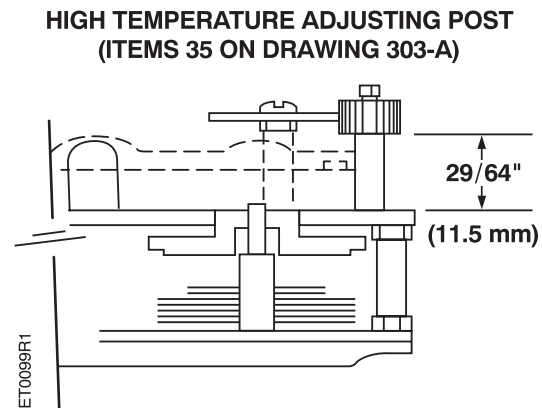

Figure 2.

All references are to the above figures or to *Figure 3*. Pressure gauges should be accurate to the nearest 1/2 psi (3.4 kPa); the thermometer to the nearest 1/2°F (0.3°C). These instructions to be used only when adequate testing facilities exist.

Procedure

See Figure 3

1. Obtain and set up test equipment shown in *Figure 1*.
2. Check thermostat for looseness or binding of parts.
3. See that friction spring (53) is in position.
4. Connect the thermostat to a terminal head. Do not use base plate or cover.
5. Remove both day (47) and night (51) temperature dials.
6. Turn day (high temperature) (48) adjusting post until the distance from the top of the lever bearing plate to the bottom of the dial pinion is 29/64" (11.5 mm) as shown in *Figure .2*
7. Completely immerse thermostat in 70°F (21°C) water with supply pressure 18 psi (124 kPa). Carefully turn valve adjusting screw (35) until return pressure is 7-1/2 psi (51.7 kPa). Allow several minutes to ensure that entire thermostat has reached this temperature.
8. Place thermostat in 60°F (15°C) water with supply pressure 25 psi (172 kPa). Turn the night (low temperature) adjusting post until return pressure is 7-1/2 psi (51.7 kPa).

Procedure, Continued

9. Recheck back at 70°F (12°C) supply pressure 18 psi (124 kPa). Return pressure should be 7-1/2 psi (51.7 kPa) or \pm 1-1/2 psi (10.3 kPa).
 10. Recheck back at 60°F (15°C) supply pressure 25 psi (172 kPa). Return pressure should be 7-1/2 psi (51.7 kPa) \pm 1-1/2 psi (10.3 kPa).
 11. If return pressure is not within these limits, check for a faulty disc or rubbing and binding of moving parts.
 12. Carefully replace the day and night temperature dials so that the day dial reads 70°F (21°C) and the night dial reads 60°F (15°C).
 13. Check changeover pressure as mentioned in item 9, *Field Calibration*.
-

Construction

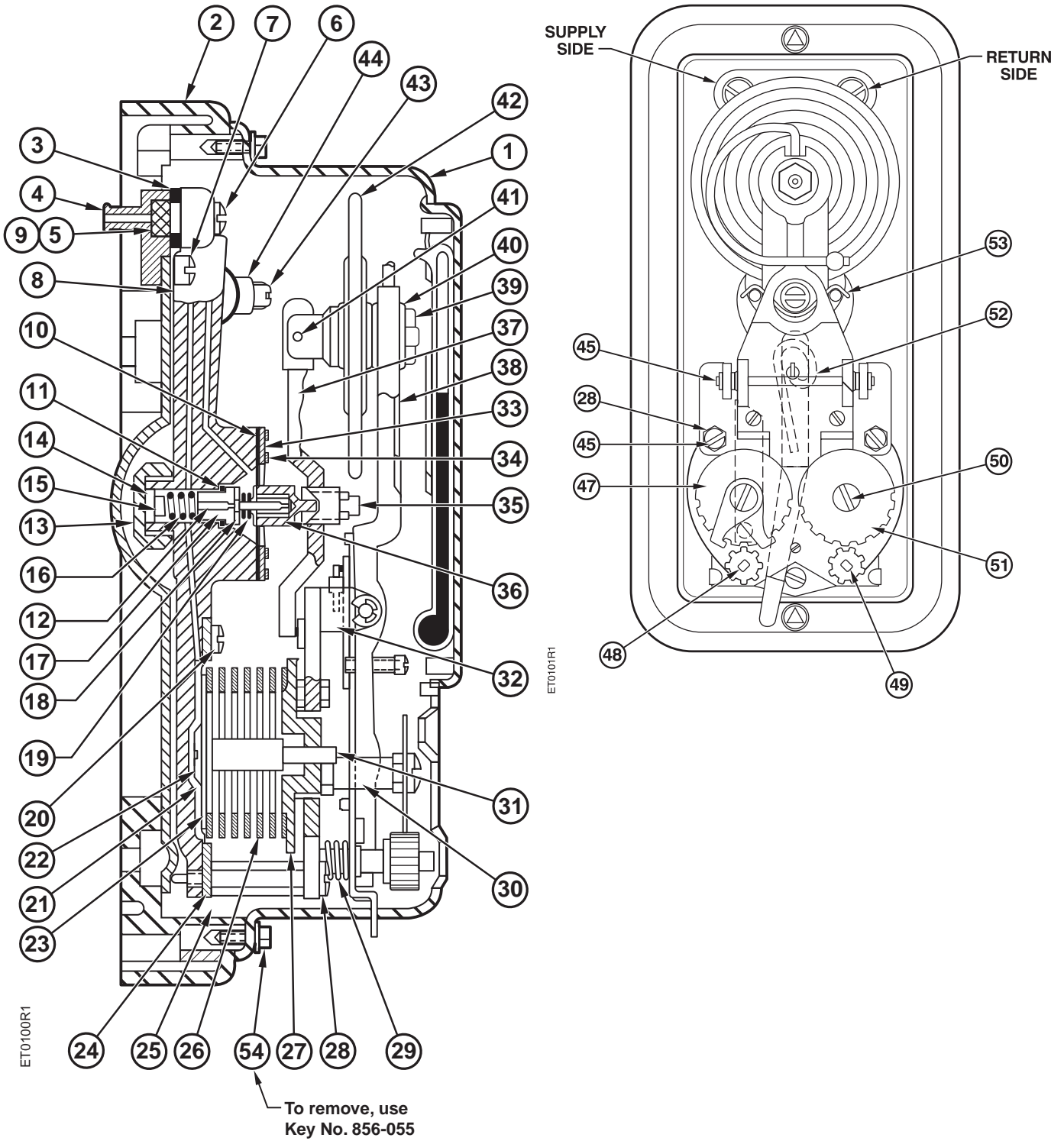

Figure 3.

Parts Lists (See Figure 3)

Item	Description	Part No.	Kit No.*
1	Cover & Grad Plate Assy. For: 832-1120 832-1140	— —	
2	Base & Finish Plate Assembly	—	
3	Gasket	838-007	A, B
4	Terminal Head	—	
5	Filter Disc	—	
6	Screw	030-045	A
7	Screw	—	
8	Frame	—	
9	Filter (Screen)	833-078	B
10	Diaphragm	833-025	B
11	Supply Valve Gasket	—	
12	Supply Valve Body	—	
13	Supply Valve Cap	—	
14	Supply Valve Cap Gasket	833-026	B
15	Spring Spacer	—	
16	Supply Valve Spring	837-009	B
17	Exhaust Valve Stem	—	
18	Supply Valve Stem	—	
19	Spring	833-072	B
20	Screw	—	
21	Diaphragm	—	
22	Diaphragm Plate Screw	—	
23	Diaphragm Plate	—	
24	Diaphragm Ring	—	
25	Spring Retainer Support	—	
26	Spring	—	
27	Spring Retainer	—	
28	Screw	—	

Item	Description	Part No.
29	Spring	—
30	Dial Support	—
31	Diaphragm Plate Extension	—
32	Lever Bearing Plate	—
33	Diaphragm Ring	—
34	Screw	—
35	Valve Adjusting Screw	—
36	Exhaust Valve Body	—
37	Control Lever	—
38	Adjustment Lever Assy.	—
39	Nut	—
40	Lockwasher	—
41	Control Lever Pivot Pin	—
42	Thermal Assembly	—
43	Seal Screw	—
44	Test Valve Body	—
45	Retainer Ring	—
46	Spring Retainer Support	—
47	Dial (Day)	—
48	Adj. Screw & Pinion (Day)	—
49	Adj. Screw & Pinion (Night)	—
50	Dial Retainer Screw	—
51	Dial (Night)	—
52	Lever Pivot Pin	—
53	Friction Spr. (0.031 dia) Music Wire	—
54	Cover Screw (Supplied with Cover)	—
Not Shown	Miscellaneous Parts Kit (For mounting to Powerstar Wall Box)	832-180

NOTE: Replacement Kit No. 182-041 consists of thermostat less cover and base.

* Included in Kit: A 182-041
 B 832-164

Accessories	Part Number
"D" Base for Exposed Tubing	832-034
Adjustment Key	856-055
Gym Guard	814-018
Friction Knob (not in catalog)	833-033

Service Parts	Part Number
Replacement Unit (Chassis only)	182-041
Exhaust & Supply Valve Repair Kit	832-164
Cover Assembly	
Concealed Adjust	181-054
Key Adjust	181-189

Dimensions

TH 832 "D" DAY-NIGHT ROOM THERMOSTAT

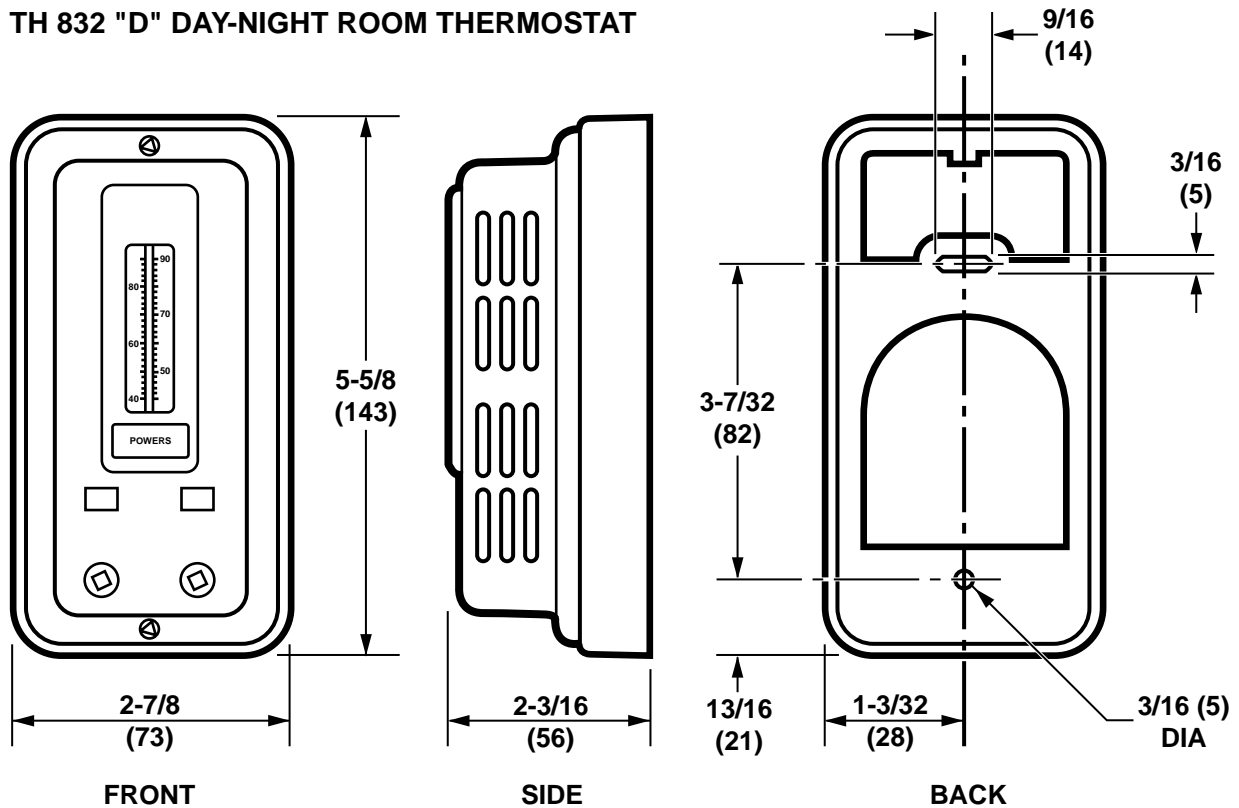

TH0366R1

FRONT
WEIGHT: 5 LBS. (2.3 KG)
DIMENSIONS IN PARENTHESES ARE IN MILLIMETERS.

SIDE

BACK

Figure 4. Dimensions.

Information in this publication is based on current specifications. The company reserves the right to make changes in specifications and models as design improvements are introduced. Powers is a trademark of Siemens Building Technologies, Inc. © 2000 Siemens Building Technologies, Inc.