

**PARAGON®**

**8000  
Series**

**MECHANICAL  
DEFROST  
TIMER**



## As Easy As 1 – 2 – 3

### 1. Set Time

Rotate knob counter-clockwise to desired time.

### 2. Set Defrost

Insert pin(s) to desired defrost time(s) on outer dial.

### 3. Set Defrost Duration

Move copper pointer to desired duration of defrost time on inner dial.

Install our Commercial Defrost Controls today to understand why Paragon® is Simply the Right Choice™ in Defrost Timers.

EPR Edgemont Precision Rebuilders, Inc  
Matlack Industrial Center  
207 Carter Dr Unit C  
West Chester, PA 19382  
800-356-3774

## Features and Benefits

Designed for commercial freezers and refrigerators, Paragon® Commercial Defrost Controls have been reliably providing automatic defrost capability for decades. They accommodate various types of defrost systems including electric defrost heaters, hot gas and compressor off cycle.

- Time initiated; temperature, pressure, or time terminated models available
- High-amp switch contacts, 40 amps, 2 HP
- Positive slider bar switch design assures positive electrical contact and wipes the contact surface of contaminants
- Temperature or Pressure Terminated models are designed for defrost termination using an external temperature or pressure device
- Safety back-up – mechanical time-driven defrost termination
- Heavy-duty synchronous design drive motor
- Choice of three contact arrangements
- Adjustable frequency of defrost initiation from 1 to 6 cycles per day with a minimum of 4 hours between successive operations
- Adjustable back-up defrost termination from 4 to 110 minutes in 2 minute increments
- Heavy-duty steel enclosure with knockouts (on the bottom, back and sides) and hasp and staple padlock

An ISO 9001 – 2008 Certified Company

**1** Year  
Limited  
Warranty



# 8000 Series

# MECHANICAL DEFROST TIMER

EPRI Edgemont Precision Rebuilders, Inc  
 Matlack Industrial Center  
 207 Carter Dr Unit C  
 West Chester, PA 19382  
 800-356-3774

## Ordering Information

Model Number		Time Initiated, Time Terminated	Time Initiated, Temperature or Pressure Terminated
120V AC	208/240V AC		
8041-00	8041-20	.	
8045-00	8045-20	.	
8047-00	8047-20	.	
8141-00	8141-20		.
8143-00	8143-20		.
8145-00	8145-20		.

Pins Indicate Defrost Start Time

Time of Day

Defrost Duration

Solid Copper Contacts  
 Line Voltage –  
 120/208-240V AC  
 40 Amp, 2 HP

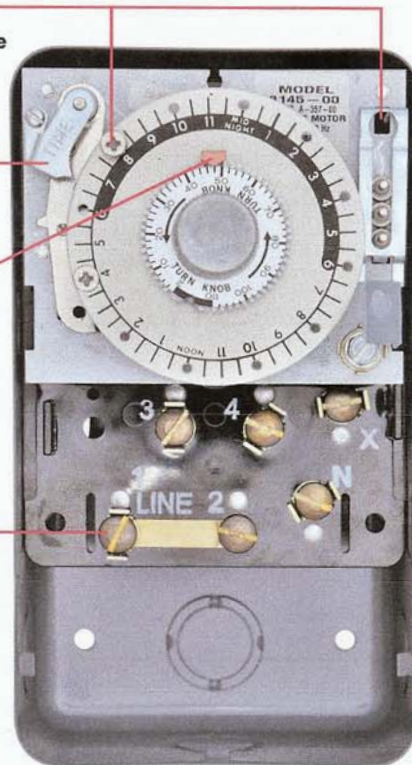

## 8040 Series Specifications

Uni-Line Part No.	Volts 60 Hz	Description	Switch arrangement contacts 2-4	Switch arrangement contacts 1-3	Switch arrangement contacts 3-N	Adj. length of defrost
8041-00	120	For Electric Heat Defrosting (Auxiliary Contact Models), Bracket available	Closed	Open	Closed	4-110 Min.
8041-20	208-240	For Electric Heat Defrosting (Auxiliary Contact Models), 50 Hz available	Closed	Open	Closed	4-110 Min.
8045-00	120	For Electric Heat, Hot Gas, or Compressor Shutdown Defrosting, Bracket available	Closed	Open	None	4-110 Min.
8045-20	208-240	For Electric Heat, Hot Gas, or Compressor Shutdown Defrosting, Bracket and 50 Hz available	Closed	Open	None	4-110 Min.
8047-00	120	For Electric Heat Defrosting (Auxiliary Contact Models)	Open	Open	Closed	4-110 Min.
8047-20	208-240	For Electric Heat Defrosting (Auxiliary Contact Models), 50 Hz available	Open	Open	Closed	4-110 Min.

## 8140 Series Specifications

Uni-Line Part No.	Volts 60 Hz	Normal Position of Contacts During Refrigeration Cycle/Contact 3-N	Normal Position of Contacts During Refrigeration Cycle/Contact 1-3	Normal Position of Contacts During Refrigeration Cycle/Contact 2-4	Comments
8141-00	120	Closed	Open	Closed	Bracket available and 50 Hz
8141-20	208-240	Closed	Open	Closed	Bracket available and 50 Hz
8143-00	120	Open	Closed	Open	Bracket available
8143-20	208-240	Open	Closed	Open	Bracket available
8145-00	120	None	Open	Closed	Bracket available and 50 Hz
8145-20	208-240	None	Open	Closed	Bracket available and 50 Hz

### Applications and Wiring Diagrams

### WIRING DIAGRAMS FOR 8040 SERIES

#### ELECTRIC HEAT DEFROSTING

MODELS 8045-00 AND 8045-20

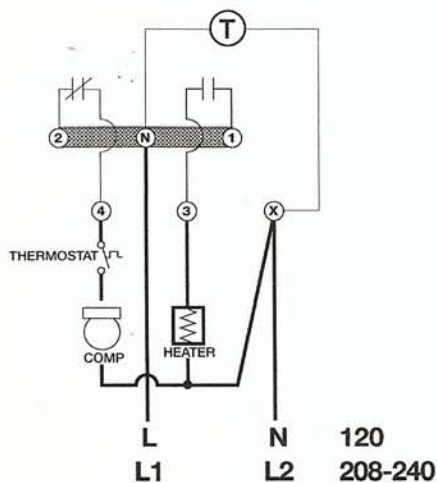

Heater not to exceed 4000 watts at 120VAC or 8000 watts at 240VAC.

#### ELECTRIC HEAT DEFROSTING

MODELS 8041-00 AND 8041-20

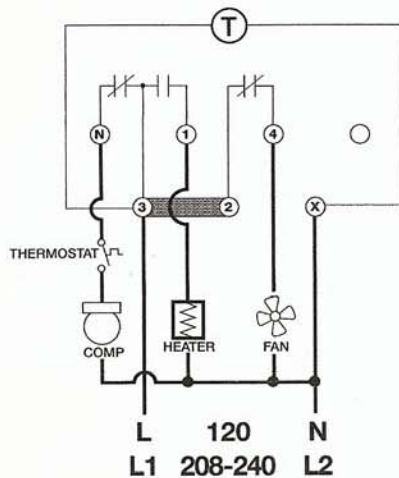

Fan and compressor loads not to exceed 2 hp. Heater not to exceed 4000 watts at 120V AC or 8000 watts at 240V AC.

EPRI Edgemont Precision Rebuilders, Inc  
Matlack Industrial Center  
207 Carter Dr Unit C  
West Chester, PA 19382  
800-356-3774

#### Key to Symbols

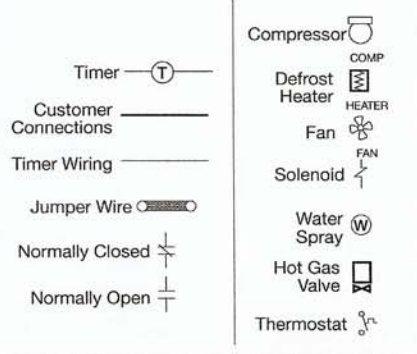

MODELS 8047-00 AND 8047-20

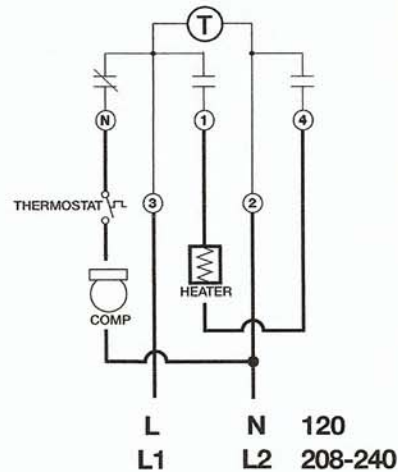

The method of wiring shown is for an electric heat defrost system breaking both sides of the heater circuit.

### Applications and Wiring Diagrams

#### WIRING DIAGRAMS FOR 8140 SERIES HOT GAS DEFROSTING

MODELS 8143-00 AND 8143-20

MODELS 8145-00, 8145-20 AND E357-00

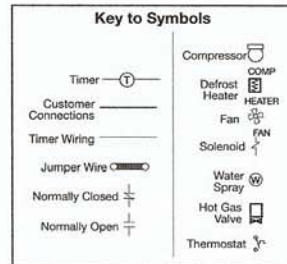
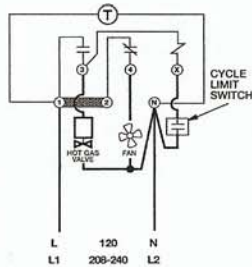
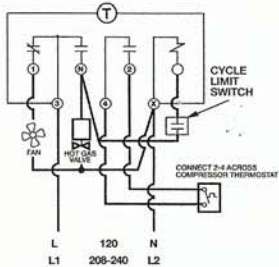

Wiring using 120V or 240V single phase line hot gas solenoid valve voltage common to timer. Refrigeration Cycle: Fan ON, hot gas solenoid valve closed, compressor ON. Defrost Cycle: Fan OFF, hot gas solenoid valve open, compressor ON.

Wiring using 120V or 240V single phase line with compressor thermostat closed during defrost.

#### ELECTRIC HEAT DEFROSTING

MODELS 8141-00 AND 8141-20

MODELS 8141-00 AND 8141-20

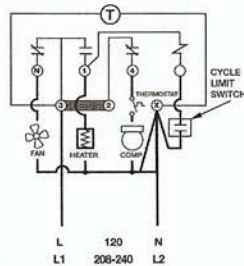
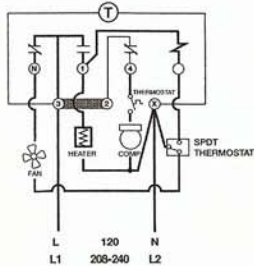

Wiring using differential of SPDT thermostat to delay fan after defrosting.

Wiring using 120V or 240V single phase line with auxiliary fan circuit.

MODELS 8143-00 AND 8143-20

MODELS 8145-00 AND 8145-20

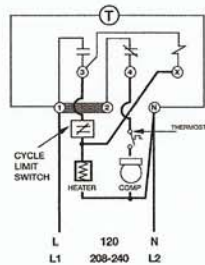
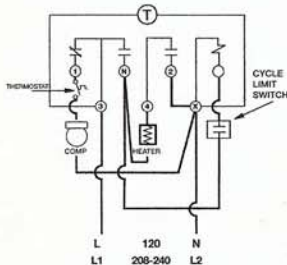

Wiring using 240V single phase line breaking both sides of heater circuit.

Normally closed thermostat used with defrost heater. Wiring using 120V or 240V single phase line compressor voltage common to timer.

**inven:sys**  
Controls

191 E. North Avenue  
Carol Stream Illinois 60188 USA  
Customer Service Telephone 1.800.304.6563  
Customer Service Facsimile 1.800.426.0804  
HVACCustomerService@Invensys.com

For Technical Service  
Telephone 1.800.445.8299  
Facsimile 1.630.260.7294  
TechnicalService@Invensys.com

Invensys™, Uni-Line® and Simply the Right Choice™ are trademarks of Invensys plc., its subsidiaries and/or affiliated companies. All other brands mentioned may be the trademarks of their respective owners.

www.Uni-Line.com  
www.InvensysControls.com  
©2010 Invensys Controls  
2/10 - 150-2230

EPRI Edgemont Precision Rebuilders, Inc  
Matlack Industrial Center  
207 Carter Dr Unit C  
West Chester, PA 19382  
800-356-3774