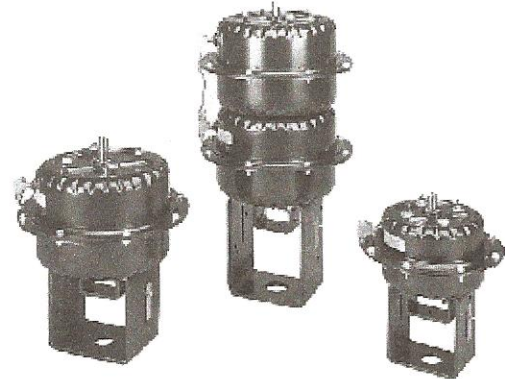


**MP8000 Series
Pneumatic Valve Actuators**

MP8000 Series Pneumatic Valve Actuators are designed to accurately position chilled water, hot water, and steam control valves in response to a pneumatic signal from a controller. A pneumatic or electric valve positioner can be ordered separately for use in applications where sequential operation is desired or additional positioning power is necessary. MP8000 Series actuators have a molded, synthetic rubber diaphragm contained in a sturdy, corrosion-resistant housing that protects against dirt and damage. This molded diaphragm provides a constant effective area throughout the actuator stroke.



**Figure 1: MP8000 Series
Pneumatic Valve Actuators**

Features and Benefits	
<input type="checkbox"/> Designed for Use in Hot Water, Chilled Water, and Steam Applications	Allows for universal application
<input type="checkbox"/> Field-Reversible Action	Allows for selectable spring-return-up or spring-return-down action on Normally Open (N.O.) valves
<input type="checkbox"/> Corrosion-Resistant Housing	Ensures long life by providing strength and corrosion resistance
<input type="checkbox"/> Position Indicator Included with Every Actuator	Provides visual indication of valve stem position

EPRI Edgemont Precision Rebuilders, Inc
Matlack Industrial Center
207 Carter Dr Unit C
West Chester, PA 19382
800-356-3774

Table 1: Ordering Data

M	P	8								Pneumatic	
1	2	3								Valve Actuator	
			2								Size and Action
			4								2 = 25 sq in. (Size 150), Spring-Return-Up 3 = 25 sq in. (Size 150), Spring-Return-Down 4 = 50 sq in. (Size 300), Spring-Return-Up 5 = 50 sq in. (Size 300), Spring-Return-Down 6 = 100 sq in. (Size 600), Spring-Return-Up 7 = 100 sq in. (Size 600), Spring-Return-Down
			1								Stroke
			5								1 = 5/16 in. (MP82 and MP83 Series Actuators) 2 = 1/2 in. (MP82 and MP83 Series Actuators) 3 = 3/4 in. (MP82, MP83, MP84, and MP85 Series Actuators) 4 = 1 in. (MP84 and MP85 Series Actuators) 5 = 1-1/8 in. (MP84, MP85, MP86, and MP87 Series Actuators) 7 = 1-1/2 in. (MP86 and MP87 Series Actuators)
			C								Spring Range
			6								C = 3 to 7 psig (Suggested for N.O. Valves with Positioner) D = 4 to 8 psig (Suggested for Three-Way Valves with Positioner) E = 9 to 13 psig (Suggested for N.C. Valves with Positioner)
			0	0	1					Yoke	
			7	8	9					001 = Factory-Mounted Yoke	
			B								Valve Mounting Kit (Optional)
			10								A = 1, 1-1/4, 1-1/2, and 2 in. Valves (VG7000 Series Stainless Steel or Brass Trim, MP82 or MP83 Actuator) B = 1/2 and 3/4 in. Valves (VG7000 Series Stainless Steel Trim, MP82 or MP83 Actuator) C = 1-1/2 and 2 in. Valves (VG7000 Series Stainless Steel Trim, MP84 or MP85 Actuator) D = 1-1/2 and 2 in. Valves (V-5000 Series Cage Trim, MP82 or MP83 Actuator) E = 2-1/2 and 3 in. Valves with "L" Stem (3/8 in.) (VG2000 Series Flanged Cast Iron, MP82 or MP83 Actuator) F = 2-1/2, 3, and 4 in. Valves with "M" Stem (3/8 in.) (VG2000 Series Flanged Cast Iron, MP84 or MP85 Actuator) G = 3, 4, 5, and 6 in. Valves with "N" Stem (1/2 in.) (VG2000 Series Flanged Cast Iron, MP86 or MP87 Actuator)

1 2 3 4 5 6 7 8 9 10 = Field

M	P	8	2	1	C	0	0	1	B
Pneumatic Valve Actuator									

Example: Pneumatic valve actuator, 25 sq in. (size 150), spring-return-up, 5/16 in. stroke, 3 to 7 psig spring range, with factory-mounted yoke and optional valve mounting kit.

Note: To order an MP8000 Series Pneumatic Valve Actuator factory mounted on a VG7000 Series Bronze Control Valve, refer to the *VG7000 Series Bronze Control Valves Product/Technical Bulletin (LIT-977140)*. To order an MP8000 Series Pneumatic Valve Actuator factory mounted on a VG2000 Series Cast Iron Flanged Globe Valve, refer to the *VG2000 Series Cast Iron Flanged Globe Valves Product/Technical Bulletin (LIT-977133)*.

Operation

Air pressure from a pneumatic controller is applied to the diaphragm of the actuator, which moves the piston against the fluid and actuator spring forces. The piston will move the valve stem and plug until the diaphragm pressure balances the actuator return spring force and the fluid forces. Reducing the air pressure permits the spring to return the valve plug to its normal position. With no control air pressure applied to the diaphragm, the valve is in the normal position.

For applications requiring stable, accurate control and sequencing, a V-9502 Pneumatic Valve Actuator Positioner or an EPP-1000 Electro-Pneumatic Actuator Positioner is available for mounting in the field. Refer to Table 3 for a list of positioners and positioner mounting kits available.

Both styles of positioners are factory calibrated to match the nominal spring range of the valve and actuator assembly. For more information regarding these positioners, refer to the *V-9502 Pneumatic Valve Actuator Positioner Product Bulletin (LIT-977265)* or the *EPP-1000 Series Electro-Pneumatic Positioners Product Bulletin (LIT-2681270)*.

Accessories

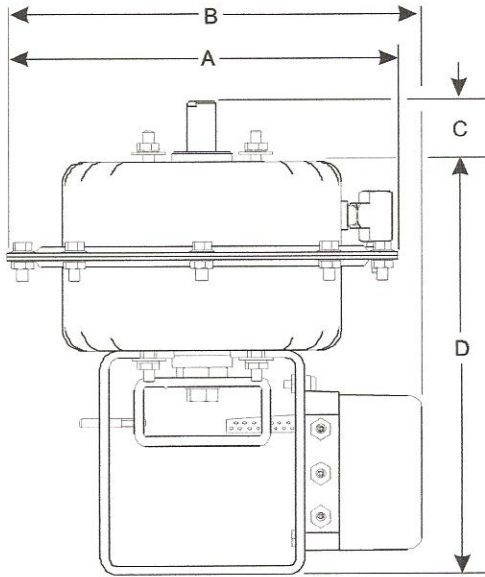
Table 2: Mounting Kits (For Field Assembly)

Description	Code Number
Mounting Kit for MP82, MP83, MP84, or MP85 Series Actuators Mounted to 2-1/2, 3, or 4 in. VG2000, V-5252, V-5462, or V-5842 Cast Iron Flanged Globe Valves with 3/8 in. Stem (Kit Includes: Two Stem Hex Jam Nuts and One Locknut)	MP8000-6201
Mounting Kit for MP86 or MP87 Series Actuators Mounted to 3, 4, 5, or 6 in. VG2000, V-5252, V-5462, or V-5842 Cast Iron Flanged Globe Valves with 1/2 in. Stem (Kit Includes: Two Stem Hex Jam Nuts and One Locknut)	MP8000-6203
Mounting Kit for MP82 or MP83 Series Actuators Mounted to 1-1/2 or 2 in. V-5254, V-5464, or V-5844 Series Cage Trim Valves with 1/4 in. Stem (Kit Includes: One Stem Nut, One Stem Extender, Two Stem Extender Nuts, and One Yoke Nut)	MP8000-6501
Mounting Kit for MP82 or MP83 Series Actuators Mounted to 1/2 or 3/4 in. VG7000 Series Bronze Control Valves with Stainless Steel Trim (Kit Includes: One Stem Nut, One Stem Extender, Two Stem Extender Nuts, and One Yoke Nut)	MP8000-6701
Mounting Kit for MP82 or MP83 Series Actuators Mounted to 1 through 2 in. VG7000 Series Bronze Control Valves with 1/4 in. Stem and Stainless Steel or Brass Trim (Kit Includes: One Stem Nut, One Stem Extender, Two Stem Extender Nuts, and One Yoke Nut)	MP8000-6702
Mounting Kit for MP84 or MP85 Series Actuators Mounted to 1-1/2 or 2 in. VG7000 Series Bronze Control Valves with 3/8 in. Stem and Stainless Steel Trim (Kit Includes: Two Stem Nuts and One Yoke Nut)	MP8000-6703

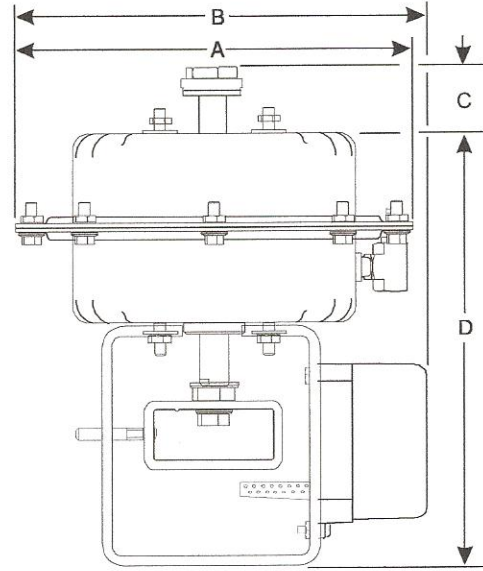
Table 3: Positioners and Positioner Mounting Kits (Order Separately)

Description	Code Number
Pneumatic Valve Actuator Positioner (Less Spring and Mounting Hardware)	V-9502-95
Mounting Kit for V-9502-95 Pneumatic Valve Actuator Positioner (Kit Includes All Necessary Mounting Hardware and Six Springs)	MP8000-6002
Electro-Pneumatic Valve Actuator Positioner (Less Mounting Hardware)	EPP-1000-8
Mounting Kit for EPP-1000-8 Electro-Pneumatic Valve Actuator Positioner (Kit Includes All Necessary Mounting Hardware)	MP8000-6003

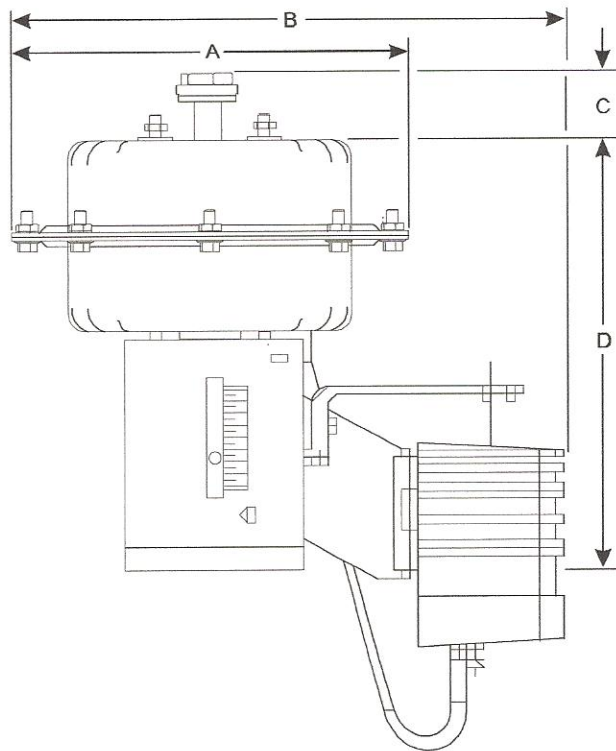
Dimensions



**Figure 2: MP82/MP84 Series
Spring-Return-Up Actuator Shown with
V-9502-95 Pneumatic Valve Actuator Positioner
(Refer to Table 4.)**

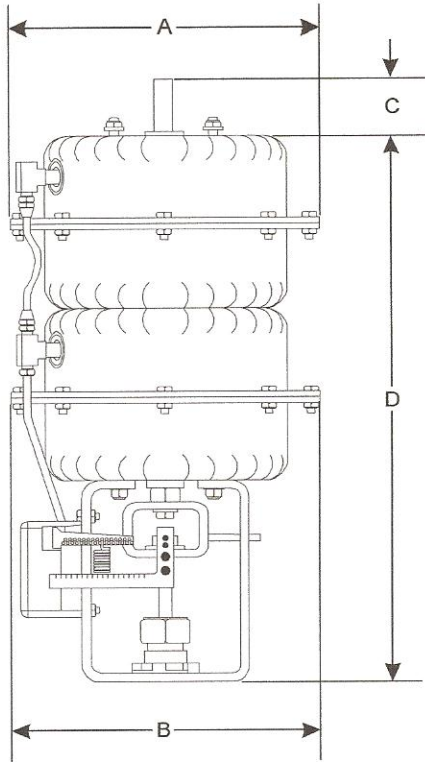


**Figure 3: MP83/MP85 Series
Spring-Return-Down Actuator Shown with
V-9502-95 Pneumatic Valve Actuator Positioner
(Refer to Table 4.)**

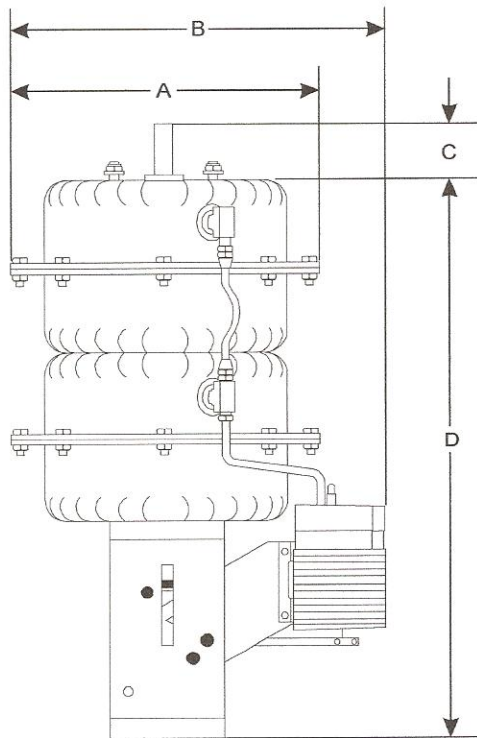


**Figure 4: MP83/MP85 Series Spring-Return-Down Actuator Shown with
EPP-1000-8 Electro-Pneumatic Valve Actuator Positioner
(Refer to Table 4.)**

EPRI Edgemont Precision Rebuilders, Inc
Matlack Industrial Center
207 Carter Dr Unit C
West Chester, PA 19382
800-356-3774



**Figure 5: MP86 Series
Spring-Return-Up Actuator Shown with
V-9502-95 Pneumatic Valve Actuator Positioner
(Refer to Table 4.)**



**Figure 6: MP86 Series
Spring-Return-Up Actuator Shown with
EPP-1000-8 Electro-Pneumatic Valve Actuator Positioner
(Refer to Table 4.)**

Table 4: Actuator Dimensions, in. (mm)

Actuator Code Number	A	B		C*	D**	Clearance Required	
		With V-9502-95	With EPP-1000-8			VG2000 Series Valves	VG7000 Series Valves
MP82 Series	8-21/32 (220)	9-7/32 (234)	11-5/8 (295)	1-1/2 (38)	9-5/32 (233)	3-3/4 (95)	2 (51)
MP83 Series	8-21/32 (220)	9-7/32 (234)	11-5/8 (295)	2 (51)	9-5/32 (233)	3-3/4 (95)	2 (51)
MP84 Series	10-1/2 (267)	11-13/16 (300)	13 (330)	2-7/16 (62)	11-13/16 (300)	3-3/4 (95)	2 (51)
MP85 Series	10-1/2 (267)	11-13/16 (300)	13 (330)	2-7/8 (73)	11-13/16 (300)	3-3/4 (95)	2 (51)
MP86 Series	10-1/2 (267)	11-13/16 (300)	13 (330)	2-7/16 (62)	19-7/8 (505)	4-3/4 (121)	---
MP87 Series	10-1/2 (267)	11-13/16 (300)	13 (330)	2-7/8 (73)	19-7/8 (505)	4-3/4 (121)	---

* Dimension "C" is from the top of the actuator housing to the top of the stem in the full up position.

** Dimension "D" is from the bottom of the yoke to the top of the actuator housing.

Repair Information

Replacement diaphragm and seal kits are available for MP8000 Series Pneumatic Valve Actuators; refer to Table 5 for ordering information and additional details. For a replacement MP8000 Actuator, refer to Table 1.

Table 5: Repair Parts (Order Separately)

Description	Code Number
Seal Kit for All MP8000 Series Actuators	MP8000-6001
Diaphragm and Seal Kit for MP82 and MP83 Series Actuators	MP8000-6325
Diaphragm and Seal Kit for MP84, MP85, MP86, and MP87 Series Actuators (Two Kits Required for MP86 and MP87 Series Actuators)	MP8000-6350
Repair Tool Kit (Required for Diaphragm and Seal Replacement)	MP8000-6012*

* This kit includes a strap handle and polyester strap, stem wrench, and 7/16 in. hex tool.

EPRI Edgemont Precision Rebuilders, Inc
Matlack Industrial Center
207 Carter Dr Unit C
West Chester, PA 19382
800-356-3774

Specifications

Product	MP8000 Series Pneumatic Valve Actuators	
Effective Diaphragm Area	MP82/MP83 Series Actuators	25 sq in. (Size 150)
	MP84/MP85 Series Actuators	50 sq in. (Size 300)
	MP86/MP87 Series Actuators	100 sq in. (Size 600)
Maximum Control Pressure	25 psig (172 kPa)	
Air Connection	Barbed Fitting for 1/4 in. O.D. Poly tubing	
Ambient Operating Temperature Limits	-20 to 150°F (-29 to 66°C)	
Ambient Storage Temperature Limits	-40 to 176°F (-40 to 80°C)	
Materials	Housing	Die-Formed Carbon Steel (Coated with Corrosion-Resistant Finish)
	Diaphragm	EPDM (Ethylene Propylene Diene Monomer)
	Stem Seals	Nitrile U-Cups
	Bearings	Reinforced Thermoplastic
	Yoke	Formed Steel (Coated with Corrosion-Resistant Finish)
	Spring	Chrome-Silicon Steel (Coated with Corrosion-Resistant Finish)
	Stem Components	Stainless Steel
Shipping Weight	MP82/MP83 Series Actuators	14.0 lb (6.4 kg)
	MP84/MP85 Series Actuators	31.0 lb (14.1 kg)
	MP86/MP87 Series Actuators	47.0 lb (21.3 kg)

The performance specifications are nominal and conform to acceptable industry standards. For application at conditions beyond these specifications, consult the local Johnson Controls office. Johnson Controls, Inc. shall not be liable for damages resulting from misapplication or misuse of its products.



Controls Group
507 E. Michigan Street
P.O. Box 423
Milwaukee, WI 53201

EPRI Edgemont Precision Rebuilders, Inc
Matlack Industrial Center
207 Carter Dr Unit C
West Chester, PA 19382
800-356-3774

Printed in U.S.A.
www.johnsoncontrols.com