

Description

These direct coupled 24 Vac Non-Spring Return rotary electric SmartX Actuators are designed for three-position (floating) control of dampers.

Features

- Compact, lightweight design
- Manual override
- Manual override
- 5° preload as shipped from factory
- Plenum cabling
- Feedback potentiometer models available
- cUL and UL listed; plenum versions also CE certified
- Independently adjustable dual auxiliary switches available



Applications

These actuators are used in constant or variable air volume installations for control of HVAC dampers requiring up to 44 lb-in (5 Nm) torque or 88 lb-in (10 Nm).

Product Numbers

Torque	Cabling	24 Vac Operating Voltage			
		Standard	Slope/Offset Adjustable	Dual Auxiliary Switches and Slope/Offset Adjustable	Dual Auxiliary Switches Only
44 lb-in (5 Nm)	Plenum	MF41-6043	—	—	—
88 lb-in (10 Nm)	Plenum	MF41-6083	MF41-6083-520	MF41-6083-522	MF41-6083-502



Precautions

Warning: Personal injury or loss of life may occur if you do not follow a procedure as specified.

Caution: Equipment damage or loss of data may occur if you do not follow a procedure as specified.

Specifications

Specifications	Operating voltage (G-Y1 or G-Y2):	24 Vac +20%, -15%
	Frequency:	50/60 Hz
Power Supply	Power consumption:	2.3 VA
Auxiliary Features	Feedback potentiometer: (MF41-6083-510)	0 to 1000 Ω <10 mA
	Dual auxiliary switch contact rating:	
	AC rating	24 Vac 4A resistive, 2A inductive
	DC rating	DC 2A
	Switch Range	
	Switch A	0° to 90° with 5° intervals
	Recommended range usage	0° to 45°
	Factory setting	5°
	Switch B	0° to 90° with 5° intervals
	Recommended range usage	45° to 90°
	Factory setting	85°
	Switching hysteresis	2°
Function	Torque:	
	MF41-6043	44 lb-in (5 Nm)
	MF41-6083 Series	88 lb-in (10 Nm)
	Runtime for 90° opening or closing:	
	MF41-6043	90 seconds. at 60 Hz (108 seconds at 50 Hz)
	MF41-6083 Series	125 seconds at 60 Hz (150 seconds at 50 Hz)
Nominal angle of rotation	90°	
Maximum angular rotation	95°	
Mounting	Shaft size:	Minimum shaft length 3/4-inch (20 mm)
Housing	Enclosure	NEMA Type 2 IP54 according to EN60529
	Material	Durable plastic
	Gear lubrication	Silicone-free
Ambient Conditions	Ambient temperature:	
	Operation	-25°F to 130°F (-32°C to 55°C)
	Storage and transport	-40°F to 158°F (-40°C to 70°C)
	Voltage Requirements for 6083 Series at High Temperatures:	
	Minimum Voltage:	24 Vac +20%, -10% 90°F to 130°F (32°C to 55°C)
	Ambient humidity (non-condensing)	95% rh

Agency Certification

UL 873
 cUL certified to Canadian
 Standard C22.2 No. 24-93

CE Conformity

Electromagnetic Compatibility (EMC)	89/336/EEC
Emissions standards	EN 61000-6-3:2001
Immunity standards	EN 61000-6-2:2001
Requirements for electric actuators	EN 60730-2-14:2001

Miscellaneous

Pre-cabled connection	18 AWG
Cable length	3 feet (0.9 m)
Life cycle	Five-year warranty
Dimensions	See Figure 8
Weight	1.06 lb (0.48 kg)

Actuator Components

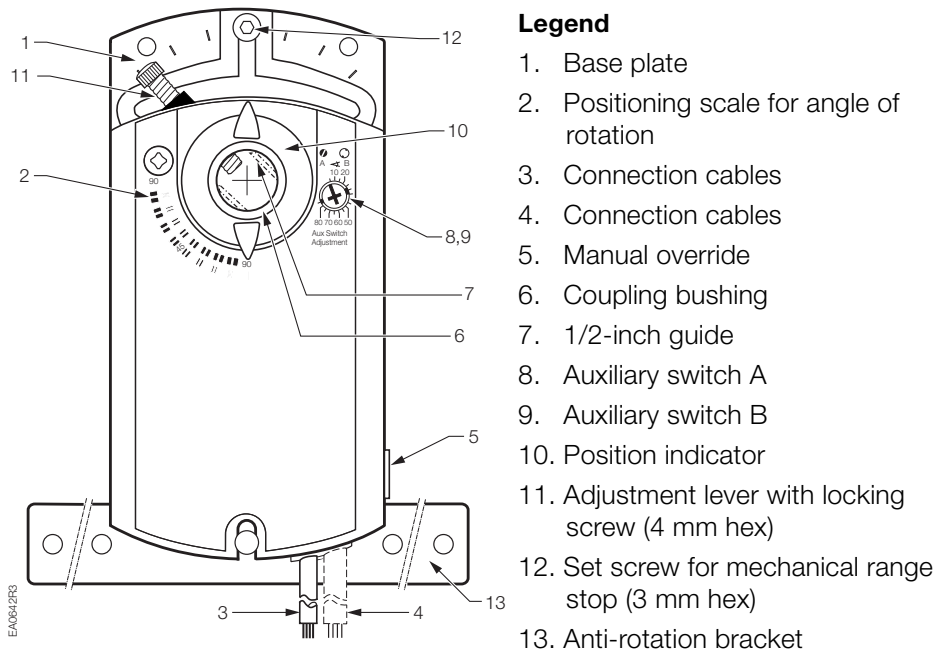

Figure 2. Parts of the Actuator.

Operation

A floating control signal controls the damper actuator. The actuator's angle of rotation is⁴ proportional to the length of time the signal is applied. A 24 Vac control signal to wires 1 and 6 (G-Y1) causes the actuator coupling to rotate clockwise. A 24 Vac control signal to wires 1 and 7 (G-Y2) causes the actuator coupling to rotate counterclockwise.

To reverse the direction of rotation, the wires 6 and 7 (Y1 and Y2) can be interchanged.

In the event of a power failure or with no control voltage, the damper actuator holds its position.

Life expectancy

An improperly tuned loop will cause excessive repositioning that will shorten the life of the actuator.

Dual Auxiliary Switch

Figure 3 shows the adjustable switching values for the auxiliary switches A and B.

Actuator Scale:
clockwise

Adjustment range for
Switches A and B

Setting interval: 5°

Switching hysteresis: 2°

Actuator Scale:
counterclockwise

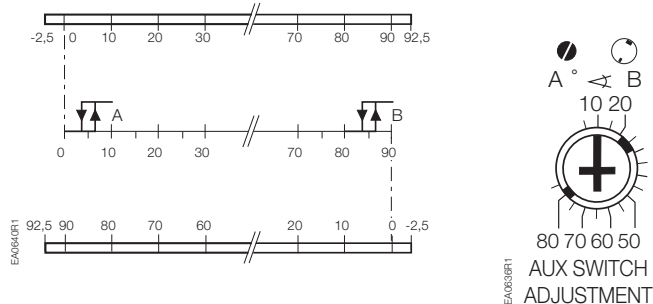

Figure 3. Adjustable Switching Values for the dual auxiliary Switches.

Notes:

- The auxiliary switch setting shafts rotate with the actuator. The scale is valid only when the actuator is in the “0” position on clockwise motion.
- For the counterclockwise rotation, the adjustment lever has to move from 90° to 0° by using the manual override and then adjust the auxiliary switches. After the auxiliary switches are adjusted, the adjustment lever has to move back to the 90° position.
- Use the long arm of the X to point to the position of switch A. Use the narrower tab on the red ring to point to the position of switch B.

Sizing

The type of actuator required depends on several factors.

1. Obtain damper torque ratings (ft-lb/ft² or Nm/m²) from the damper manufacturer.
2. Determine the area of the damper.
3. Calculate the total torque required to move the damper:

$$\text{Total Torque} = \frac{\text{Torque Rating} \times \text{Damper Area}}{\text{SF}^1}$$

¹Safety Factor: When determining the torque of an actuator required, a safety factor should be included for unaccountable variables such as slight misalignments, aging of the damper, etc. A suggested safety factor is 0.80 (or 80% of the rated torque).

4. Select the actuator type from Table 2.

Total Torque	Actuator
44 lb-in (5 Nm)	MF41-6043
88 lb-in (10 Nm)	MF41-6083 Series

Table 3.

Mounting and Installation

You must place the actuator on the damper shaft so that the front of the actuator is accessible. The label is the front side.
The minimum damper drive shaft length is 3/4-inch (20 mm).

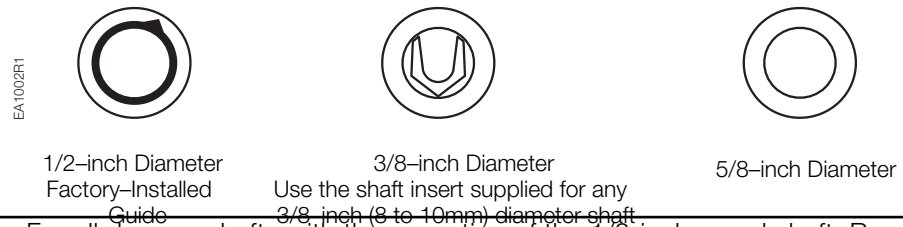

Note: For all damper shafts with the exception of the 1/2-inch round shaft: Remove 1/2-inch diameter guide before installation

Figure 4. Damper Shaft Sizes.

- An anti-rotation bracket is included with the actuator.
- Observe the service envelope around the actuator as shown in Figure 8.
- For detailed mounting instructions, see Installation Instructions F-27211.

Manual override

To move the damper blades and lock the position with no power present:

1. Slide the red manual override knob toward the back of the actuator.
2. Make adjustments to the damper position.
3. Slide the red manual override knob toward the front of the actuator.

Once power is restored, the actuator returns to automated control.

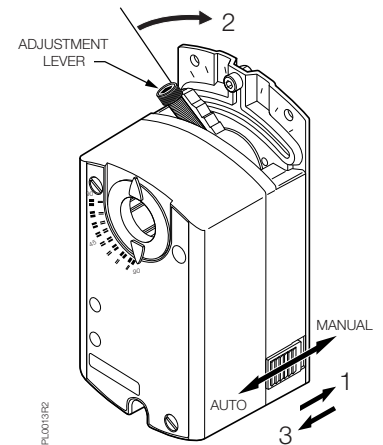

Figure 5. Manual Override.

Mechanical range adjustment

To mechanically limit the range of the damper blade.

1. Loosen the stop set screw.
2. Move the screw along the track to the desired position, and fasten it in place.

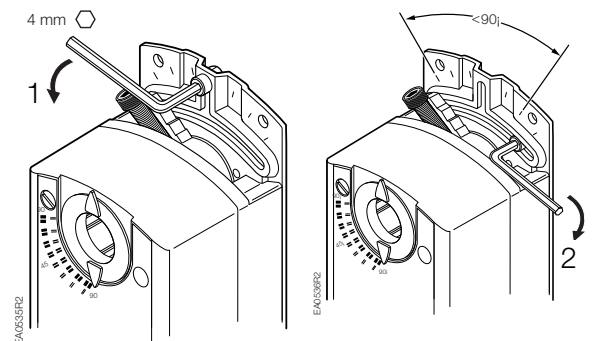

Figure 6. Moving the Mechanical Range Stop.

Wiring

All wiring must conform to NEC and local codes and regulations.

Use earth ground isolating step-down Class 2 transformers.

Do not use autotransformers.

The sum of the VA ratings of all actuators and all other components powered by one transformer must not exceed the rating of the transformer. It is recommended that one transformer power no more than 10 actuators.

Caution: Do not wire different types of actuators (such as MS/MF41-6153 Series) in parallel with these models.



Warning: All six outputs of the dual auxiliary switch (A and B) must only be connected to: Class 2 voltage (UL/C-UL).

Separated Extra-Low Voltage (SELV) or Protective Extra Low Voltage (PELV) (according to HD384 4 41) for installations requiring CE conformance. You must use a CE certified plenum actuator.



Warning: Installations requiring CE Conformance:

- All wiring for CE certified actuators must only be separated extra low voltage (SELV) or protective extra low voltage (PELV) per HD384-4-41.
 - Use safety-isolating transformers (Class III transformer) per EN61558. They must be rated for 100% duty cycle.
 - Overcurrent protection for supply lines is maximum 10A.
-

Direction of damper rotation

To reverse the direction of rotation, wires 6 (violet) and 7 (orange) can be interchanged.

Wire Designations

Each wire has the standard symbol printed on it.

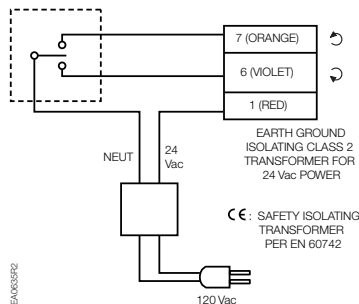
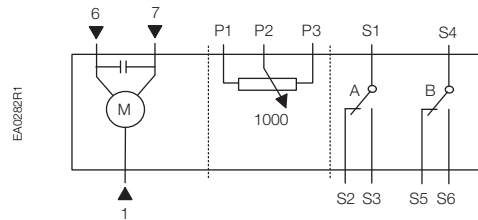

Figure 7. Three-position Control.

Table 3. Three-position Control 24 Vac.

Wire Designations Continued

24 Vac power supply Three-position control 24 Vac



Standard Symbol	Function	Color
1	Supply (SP)	Red
6	Control signal clockwise	Violet
7	Control signal counterclockwise	Orange
Factory-installed options		
S1	Switch A Common	Black
S2	Switch A N.C.	
S3	Switch A N.O.	
S4	Switch B Common	
S5	Switch B N.C.	
S6	Switch B N.O.	
P1	Feedback Potentiometer 0 to 100% P1 - P2	Black
P2	Feedback Potentiometer Common	
P3	Feedback Potentiometer 100 to 0% P3 - P2	

Start-Up/Commissioning

Check that the wires are connected correctly. Connect wires 1 (red) and 6 (violet) to a Digital Multimeter (DMM) with the dial set at Vac. Apply a control signal (24 Vac) to wires 1 and 6 to verify that the operating voltage is within range. Connect wires 1 (red) and 7 (orange) to a DMM with the dial set at Vac. Apply a control signal (24 Vac) to wires 1 and 7 to verify that the operating voltage is within range.

1. Check operation:
 - a. Connect wire 1 (red) to the actuator.
 - b. Apply a control signal (24 Vac) to wires 1 (red) and 6 (violet).
 - c. Allow the actuator shaft coupling to rotate from 0° to 90°.
 - d. Stop applying a control signal to wires 1 (red) and 6 (violet).
 - e. Apply a control signal (24 Vac) to wires 1 (red) and 7 (orange).
 - f. Allow the actuator shaft coupling to rotate from 90° to 0°.
2. Check Feedback:
 - a. Set the DMM dial to ohms.
 - b. Connect wires P1 and P2 to the DMM. The DMM should indicate a resistive value.
 - c. Apply a control signal (24 Vac) to wires 1 (red) and 6 (violet). The reading of the DMM should increase.
 - d. Connect wires P2 and P3 to the DMM. The DMM should indicate a resistive value.
 - e. Apply a control signal (24 Vac) to wires 1 (red) and 7 (orange). The reading of the DMM should increase.
3. Check Auxiliary Switch A:
 - a. Set the DMM dial to ohms (resistance) or continuity check.
 - b. Connect wires S1 and S3 to the DMM. The DMM should indicate an open circuit or no resistance.
 - c. Apply a control signal (24 Vac) to wires 1 (red) and 6 (violet). The DMM should indicate contact closure as the actuator shaft coupling reaches the setting of switch A.
 - d. Stop applying a control signal to wires 1 (red) and 6 (violet).
 - e. Connect wires S1 and S2 to the DMM. The DMM should indicate an open circuit or no resistance.
 - f. Apply a control signal (24 Vac) to wires 1 (red) and 7 (orange).
 - g. The DMM should indicate contact closure as the actuator shaft coupling reaches the setting of switch A.

Start-Up/ Commissioning Continued

- 4 Check the Auxiliary Switch B:
 - a. Set the DMM dial to ohms (resistance) or continuity check.
 - b. Connect wires S4 and S6 to the DMM. The DMM should indicate an open circuit or no resistance.
 - c. Apply a control signal (24 Vac) to wires 1 (red) and 6 (violet). The DMM should indicate contact closure as the actuator shaft coupling reaches the setting of switch B.
 - d. Stop applying a control signal to wires 1 (red) and 6 (violet).
 - e. Connect wires S4 and S5 to the DMM. The DMM should indicate an open circuit or no resistance.
 - f. Apply a control signal (24 Vac) to wires 1 (red) and 7 (orange) The DMM should indicate contact closure as the actuator shaft coupling reaches the setting of switch B.

Service

Warning: Do not open the actuator. If the actuator is inoperative, replace the unit.

Dimensions

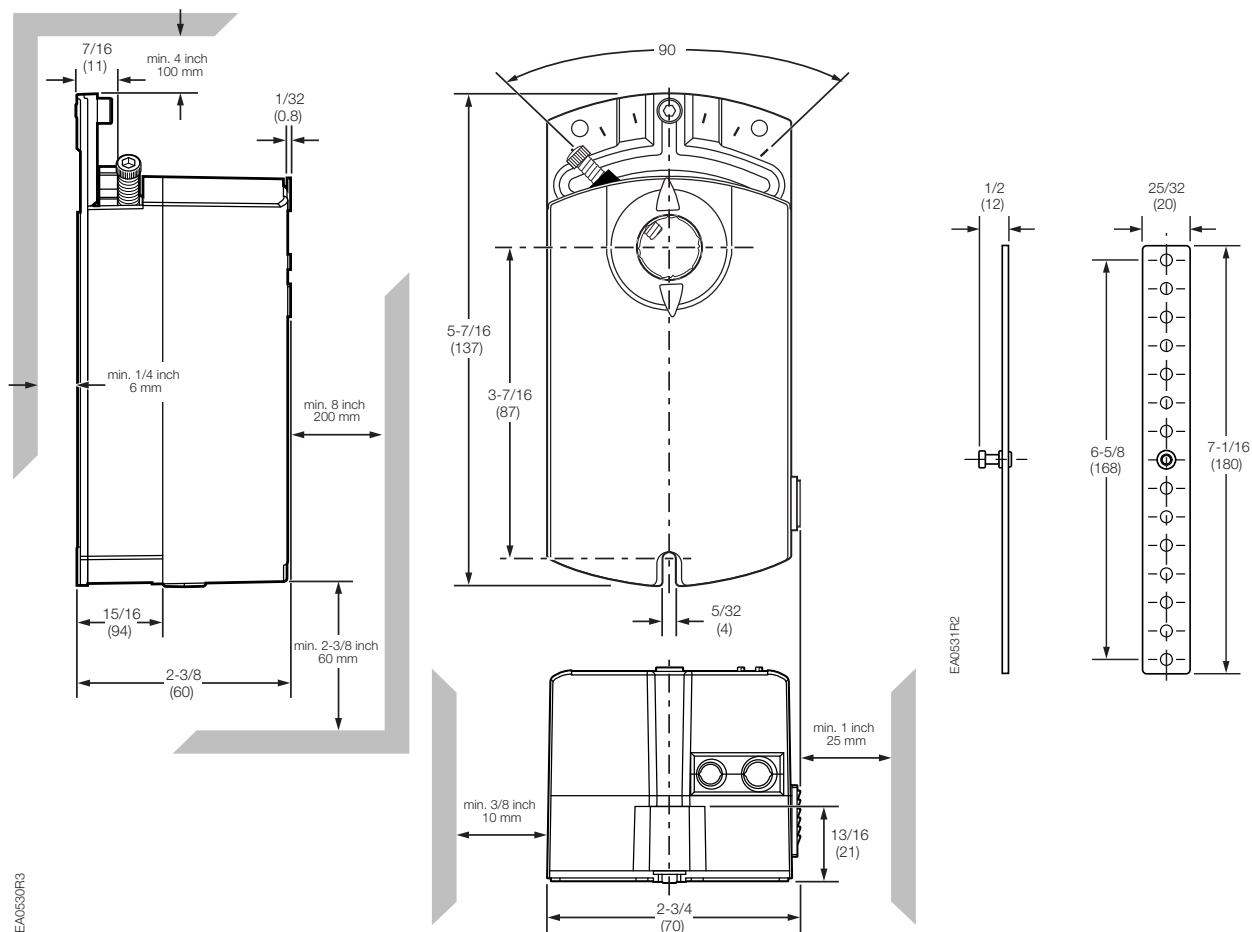

Figure 8. Dimensions of the SmartX Actuator and Anti-rotation Bracket.