

M9210-xxx-3 Electric Spring Return Actuators

Product Bulletin

Code No. LIT-12011056
Issued June 1, 2009
Supersedes February 4, 2009

The M9210-xxx-3 Series Actuators are direct mount, spring return electric actuators that operate on these available power options:

- AC 24 V at 50/60 Hz or DC 24 V (AGx, Bxx, GGx, HGx)
- AC 120 V at 60 Hz (BAx)
- AC 230 V at 50/60 Hz (BDx)

These bidirectional actuators do not require a damper linkage, and are easily installed on dampers with 1/2 to 3/4 in. or 12 to 19 mm round shafts, or 3/8 and 1/2 in. or 10, 12, and 14 mm square shafts using the standard shaft clamp included with the actuator. An optional M9220-600 Jackshaft Coupler Kit is available for 3/4 to 1-1/16 in. or 19 to 27 mm round shafts, or 5/8 and 3/4 in. or 16, 18, and 19 mm square shafts.

The M9210-xxx-3 Electric Spring Return Actuators provide running and spring return torques of 89 lb-in (10 N·m). Integral line voltage auxiliary switches are available on the xxC models to indicate end-stop position, or to perform switching functions within the selected rotation range.



Figure 1: M9210-xxx-3 Electric Spring Return Actuator

Table 1: Features and Benefits

Features	Benefits
Reversible Mounting Design	Simplifies installation and enables the actuator to spring return in either direction.
Electronic Stall Detection throughout Entire Rotation Range	Extends the life of the actuator by deactivating the actuator motor when an overload condition is detected.
Removable Coupler	Adapts to a shorter damper shaft.
Integral 48 in. (1.2 m) Halogen Free Cables with Colored and Numbered Conductors	Simplify field wiring.
Integral Auxiliary Switches (xxC Models)	Provide one fixed and one adjustable switch point with line voltage capability.
NEMA 2 (IP54) Rated Aluminum Enclosure	Protects the internal components of the actuator from dirt and moisture.
Easy-to-Use Locking Manual Override with Auto Release and Crank Storage	Allows for manual positioning of the actuator hub.
Integral Connectors for 3/8 in. (10 mm) Flexible Metal Conduit	Simplify installation and field wiring.
Microprocessor-Controlled Brushless DC Motor (-AGx, -GGx, and -HGx Types)	Provides constant run-time independent of torque.

Product Overview

The M9210-xxx-3 Electric Spring Return Actuators provide reliable control of dampers and valves in Heating, Ventilating, and Air Conditioning (HVAC) systems.

IMPORTANT: Use this M9210-xxx-3 Electric Spring Return Actuator only to control equipment under normal operating conditions. Where failure or malfunction of the electric actuator could lead to personal injury or property damage to the controlled equipment or other property, additional precautions must be designed into the control system. Incorporate and maintain other devices such as supervisory or alarm systems or safety or limit controls intended to warn of, or protect against, failure or malfunction of the electric actuator.

IMPORTANT: Do not install or use this M9210-xxx-3 Electric Spring Return Actuator in or near environments where corrosive substances or vapors could be present. Exposure of the electric actuator to corrosive environments may damage the internal components of the device, and will void the warranty.

Operation

The M9210-xxx-3 Actuators are available for use with on/off, floating, and proportional controllers.

On/Off Control (M9210-Bxx-3 Actuators)

When power is applied, the actuator drives open and the output hub rotates against the spring from -5 to 90°. The actuator is electronically overload protected should the actuator stall before reaching 90°. It holds position at the end of the stroke until power is removed. When power is removed, the actuator spring returns to the -5° position. An M9220-603 adjustable stop kit is available to limit the stroke of the actuator between 30 and 90° in 5° increments. M9210-BxC-3 actuators include two integral Single-Pole, Double-Throw (SPDT) auxiliary switches. One switch is set to trip at 11° as the actuator is spring return closed.

Floating Control (M9210-Axx-3 Actuators)

Note: The information in this section assumes that Side A of the actuator (Counterclockwise [CCW] spring return) is facing you and the Direct Acting/Reverse Acting (DA/RA) selector switch is set in the DA position.

The actuator receives power by applying AC/DC 24 V between the black (common) and red (+AC/DC 24 V) wires. A controller applies power between the black and gray or black and orange wires to command the actuator to drive Clockwise (CW) or CCW at a constant speed, independent of load.

Applying AC/DC 24 V between the black and gray wires causes the actuator to drive CW from -5 toward 90° at a constant speed, independent of load. The time required to drive full stroke from 0 to 90° is nominally 150 seconds. When AC/DC 24 V power between the black and gray wires is removed, the actuator stops and holds its position. The longer power is applied between the black and gray wires, the farther the actuator rotates toward the 90° position.

Applying AC/DC 24 V power between the black and orange wires causes the actuator to drive CCW toward the -5° position. The longer AC/DC 24 V power is applied between the black and orange wires, the farther the actuator travels toward the -5° position. When power between the black and orange wires is removed, the actuator stops and holds its position.

Changing the DA/RA switch from DA to RA reverses the direction the actuator drives when power is applied between the black and gray or black and orange wires. The actuator is overload protected should it stall anywhere within its stroke. If the actuator stalls, it retries once after 2 minutes, assuming AC/DC 24 V is still applied.

If power is lost between the black (common) and red (+AC/DC 24 V) wires, the actuator spring returns to the -5° position. If power between the black and red wires is momentarily interrupted, the actuator drives to the -5° position and waits for the controller to command it in either the CW or CCW direction.

Proportional Control (M9210-GGx-3 Actuators)

Note: The information in this section assumes that Side A of the actuator (CCW spring return) is facing you and the control selector switch is set to the 0...10 V CW position.

The actuator is powered with AC/DC 24 V power between the black (common) and red (+AC/DC 24 V) wires. A proportional controller provides a DC 0 to 10 V signal between the black (common) and gray (control signal input) wires.

As the control signal increases from DC 0 to 10 V, the actuator drives CW from the -5 to 90° position. The position at which the actuator stops is proportional to the control signal. The actuator provides about 120 steps of control.

As the signal decreases, the actuator reverses direction and drives CCW toward the -5° position. A DC 0 to 10 V feedback signal is provided between the black (common) and orange (DC 0 to 10 V feedback signal output) to indicate the position of the actuator.

The direction in which the actuator drives with an increasing control signal can be reversed by positioning the selector switch to the DC 0...10 V CCW position. When the actuator is placed in this position, and it is at the 90° position with a DC 0 V control signal, the actuator proportionally drives to the -5° position as the control signal increases.

The actuator spring returns when power is interrupted between the black and red wires. When power returns, the actuator drives to the fully spring-return position to establish an end-of-stroke position, then drives to the position commanded by the DC 0 to 10 V controller.

This model has a selector switch that provides operation for DC 2 to 10 V controllers. This switch allows a CW or CCW rotation as the control signal increases from DC 2 to 10 V. The feedback signal between the black and orange wires changes to DC 2 to 10 V when the input signal selector is positioned to the DC 2 to 10 V CW or CCW position.

The M9210-GGx-3 actuators can be controlled by a DC 0 to 20 mA or DC 4 to 20 mA controller by placing a field furnished 1/4 watt 500 ohm resistor between the black (common) and orange (+DC 0(4) to 20 mA control signal input) wires.

Proportional Control/Adjustable (M9210-HGx-3 Actuators)

The M9210-HGx-3 actuators operate in a similar manner to the M9210-GGx-2 actuators, except the M9210-HGx-3 actuators have an adjustable start voltage, which can be programmed between DC 0 to 10 V. The span adjustment can be programmed between a DC 2 to 10 V range, allowing the actuator to operate between DC 0 to 20 V. The M9210-HGx-3 is programmed in the factory for DC 0 to 10 V.

For this actuator, the feedback signal between the black and orange wires always provides a DC 0 to 10 V output, regardless of the start voltage or span selected.

Repair Information

A number of replacement parts are available; see Table 2 for more details. If the M9210-xxx-3 Electric Spring Return Actuator fails to operate within its specifications, replace the unit. For a replacement electric actuator, contact the nearest Johnson Controls® representative.

Ordering Information

Table 2: Electric Spring Return Actuator Models

Code Number	Control Type	Auxiliary Switches	Power Requirements
M9210-AGA-3	Floating	None	AC 24 V at 50/60 Hz or DC 24 V
M9210-AGC-3	Floating	Two	AC 24 V at 50/60 Hz or DC 24 V
M9210-BAA-3	On/Off	None	AC 120 V at 60 Hz
M9210-BAC-3	On/Off	Two	AC 120 V at 60 Hz
M9210-BDA-3	On/Off	None	AC 230 V at 50/60 Hz
M9210-BDC-3	On/Off	Two	AC 230 V at 50/60 Hz
M9210-BGA-3	On/Off	None	AC 24 V at 50/60 Hz or DC 24 V
M9210-BGC-3	On/Off	Two	AC 24 V at 50/60 Hz or DC 24 V
M9210-GGA-3	Proportional	None	AC 24 V at 50/60 Hz or DC 24 V
M9210-GGC-3	Proportional	Two	AC 24 V at 50/60 Hz or DC 24 V
M9210-HGA-3	Proportional w/Adjustable Zero and Span	None	AC 24 V at 50/60 Hz or DC 24 V
M9210-HGC-3	Proportional w/Adjustable Zero and Span	Two	AC 24 V at 50/60 Hz or DC 24 V

Table 3: Accessories and Replacement Parts (Order Separately)

Code Number	Description
DMPR-KC003¹	7 in. (178 mm) Blade Pin Extension (without Bracket) for Johnson Controls Direct-Mount Damper Applications
M9000-158	Tandem Mounting Kit used to Mount Two Models of M9220-xxx-3 Series Proportional Electric Spring Return Actuators
M9000-200	Commissioning Tool that Provides a Control Signal to Drive 24 V On/Off, Floating, Proportional, and/or Resistive Electric Actuators
M9000-153	Crank arm
M9000-170	Remote Mounting Kit, Horizontal. Kit includes Mounting Bracket, M9000-153 Crank Arm, Ball Joint, and Mounting Bolts
M9000-171	Remote Mounting Kit, Vertical. Kit includes Mounting Bracket, M9000-153 Crank Arm, Ball Joint, and Mounting Bolts
M9000-320	Weather Shield Enclosure - NEMA 3R enclosure for protecting a single M9210/20 actuator from rain, sleet, or snow
M9000-604	Replacement Anti-rotation Bracket Kit (with Screws) for M9220-xxx-3 Series Proportional Electric Spring Return Actuators
M9220-600	1 in. (25 mm) Jackshaft Coupler Kit (with Locking Clip) for Mounting M9220-xxx-3 Proportional Electric Spring Return Actuators on Dampers with 3/4 to 1-1/16 in. or 19 to 27 mm Round Shafts, or 5/8 and 3/4 in. or 16, 18, and 19 mm Square Shafts
M9220-601	Replacement Coupler Kit (with Locking Clip) for Mounting M9220-xxx-3 Proportional Electric Spring Return Actuators on Dampers with 1/2 to 3/4 in. or 12 to 19 mm Round Shafts, or 3/8 and 1/2 in. or 10, 12, and 14 mm Square Shafts
M9220-602	Replacement Locking Clips for M9220-xxx-3 Proportional Electric Spring Return Actuators (Five per Bag)
M9220-603	Adjustable Stop Kit for M9220-xxx-3 Proportional Electric Spring Return Actuators
M9220-604	Replacement Manual Override Cranks for M9220-xxx-3 Proportional Electric Spring Return Actuators (Five per Bag)
M9220-610	Replacement Shaft Gripper, 10 mm Square Shaft with Locking Clip
M9220-612	Replacement Shaft Gripper, 12 mm Square Shaft with Locking Clip
M9220-614	Replacement Shaft Gripper, 14 mm Square Shaft with Locking Clip

1. Furnished with the damper and may be ordered separately.

Dimensions

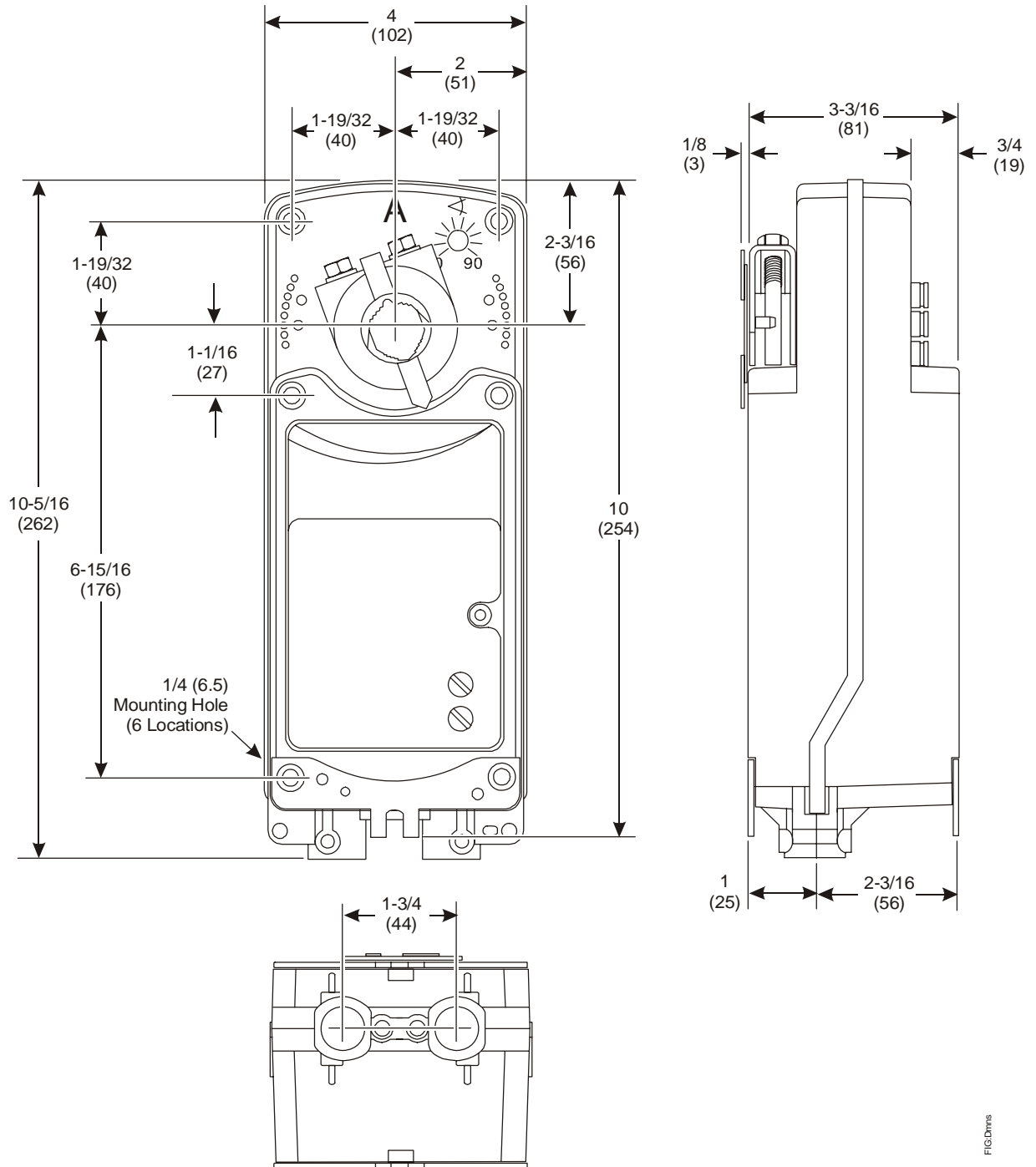

Figure 2: M9210-xxx-3 Electric Spring Return Actuator Dimensions, in. (mm)

Technical Specifications

M9210-xxx Electric Spring Return Actuators (Part 1 of 3)

Product Codes		M9210-AGx-3 Models: Floating M9210-Bxx-3 Models: On/Off M9210-GGx-3 Models: Proportional M9210-HGx-3 Models: Proportional Adjustable
Power Requirements	AGx, GGx, HGx Models	AC 24 V (19.2 to 30 V) at 50/60 Hz: Class 2, 9.6 VA Running, 6 VA Holding Position; DC 24 V (21.6 to 26.4 V); Class 2, 3.9 W Running, 2.1 W Holding Position
	BAx Models	AC 120 V (AC 102 to 132 V) at 60 Hz: 0.25 A Running, 0.13 A Holding Position
	BDx Models	AC 230 V (AC 198 to 264 V) at 50/60 Hz: 0.15 A Running, 0.09 A Holding Position
	BGx Models	AC 24 V (19.2 to 30 V) at 50/60 Hz: Class 2, 17.7 VA Running, 5.1 VA Holding Position; DC 24 V (21.6 to 26.4 V): Class 2, 15.6 W Running, 2.6 W Holding Position
Transformer Sizing Requirements	AGx, GGx, HGx Models	15 VA Minimum per Actuator
	Bxx Models	25 VA Minimum per Actuator
Input Signal/ Adjustments	AGx Models	DC 0 (2) to 10 V or 0 (4) to 20 mA with Field Furnished 500 ohm resistor; Switch Selectable Direct or Reverse Action with Signal Increase, 500 ms minimum pulse width
	GGx Models	Factory Set at DC 0 to 10 V, CW Rotation with Signal Increase; Selectable DC 0 (2) to 10 V or 0 (4) to 20 mA with Field Furnished 500 ohm, 0.25 W minimum resistor; Switch Selectable Direct or Reverse Action with Signal Increase
	HGx Models	Factory Set DC 0 to 10 V, CW Rotation with Signal Increase; Selectable DC 0 to 10 V or 0 to 20 mA with Field Furnished 500 ohm, 0.25 W minimum resistor; Start Point Programmable DC 0 to 10 V; Span Programmable DC 2 to 10 V; Switch Selectable Direct or Reverse Action with Signal Increase
Control Input Impedance	GGx, HGx Models	Voltage Input: 200,000 ohms; Current Input: 500 ohms with Field Furnished 500 ohm Resistor
Feedback Signal	HGx Models	DC 0 to 10 V for Desired Rotation Range up to 90°; Corresponds to Rotation Limits, 1 mA maximum
	GGx Models	DC 0 (2) to 10 V for Desired Rotation Range up to 90°; Corresponds to Rotation Limits, 1 mA maximum
Auxiliary Switch Rating	xxC Models	Two Single-Pole, Double-Throw (SPDT), Double-Insulated Switches with Gold Flash Contacts: AC 24 V, 50 VA Pilot Duty; AC 120 V, 5.8 A Resistive, 1/4 hp, 275 VA Pilot Duty; AC 240 V, 5.0 A Resistive, 1/4 hp, 275 VA Pilot Duty
Spring Return		Direction is Selectable with Mounting Position of Actuator: Side A, Actuator Face Away from Damper for CCW Spring Return; Side B, Actuator Face Away from Damper for CW Spring Return
Running and Spring Return Torque		89 lb-in (10 N-m)

M9210-xxx Electric Spring Return Actuators (Part 2 of 3)

Rotation Range		Adjustable from 30 to 90° CW or CCW with Optional M9210-603 Adjustable Stop Kit; Mechanically Limited to 90°
Rotation Time Power On (Running)	AGx, GGx, HGx Models	150 Seconds for 0 to 89 lb-in (0 to 10 N-m) at All Operating Conditions; Independent of Load
	Bxx Models	24 to 57 Seconds for 0 to 89 lb-in (0 to 10 N-m) at All Operating Conditions; 35 Seconds Nomimal at Full Rated Load
Rotation Time Power Off (Spring Returning)	AGx, GGx, HGx Models	26 Seconds for 0 to 89 lb-in (0 to 10 N-m) at Room Temperature
	Bxx Models	11 to 15 Seconds for 0 to 89 lb-in (0 to 10 N-m) at Room Temperature; 35 Seconds Maximum for 0 to 89 lb-in (0 to 10 N-m) at -22°F (-30°C) 130 Seconds Maximum for 0 to 89 lb-in (0 to 10 N-m) at -40°F (-40°C)
Cycles		60,000 Full Stroke Cycles, 1,500,000 repositions
Audible Noise Rating (AGx, HGx, GGx Models)	Power On (Running)	<40 dBA at 39-13/32 in. (1 m)
	Power On (Holding)	<20 dBA at 39-13/32 in. (1 m)
	Power Off (Spring Returning)	<55 dBA at 39-13/32 in. (1 m)
Audible Noise Rating (Bxx Models)	Power On (Running)	<66 dBA at 39-13/32 in. (1 m)
	Power On (Holding)	<18 dBA at 39-13/32 in. (1 m)
	Power Off (Spring Returning)	<66 dBA at 39-13/32 in. (1 m)
Electrical Connections	Actuator (All Models)	48 in. (1.2 m) Halogen-Free Cable with 18 AWG (0.75 mm ²) Wire Leads
	Auxiliary Switches (GGC Models)	48 in. (1.2 m) Halogen-Free Cable with 18 AWG (0.75 mm ²) Wire Leads
Conduit Connections		Integral Connectors for 3/8 in. (10 mm) Flexible Metal Conduit
Mechanical Connections	Standard Shaft Clamp Included with Actuator	1/2 to 3/4 in. or 12 to 19 mm Diameter Round Shafts, or 3/8 and 1/2 in. or 10, 12, and 14 mm Square Shafts
	Optional M9210-600 Jackshaft Coupler Kit	3/4 to 1-1/16 in. or 19 to 27 mm Diameter Round Shafts, or 5/8 and 3/4 in. or 16, 18, and 19 mm Square Shafts
Aluminum Enclosure		NEMA 2 (IP54) for All Mounting Orientations
Ambient Conditions	Operating	-40 to 131°F (-40 to 55°C); 90% RH Maximum, Noncondensing
	Storage	-85 to 185°F (-65 to 85°C); 95% RH Maximum, Noncondensing
Dimensions		See Figure 2.

M9210-xxx Electric Spring Return Actuators (Part 3 of 3)

Compliance	North America	UL Listed, File E27734, CCN XAPX (United States) and XAPX7 (Canada)
	Europe	CE Mark, EMC Directive 89/336/EEC (M9210-xGA-3 Models)
		CE Mark, Low Voltage Directive 73/23/EEC (M9210-BDA-3 and M9210-xxC-3 Models)
Australia and New Zealand	C-Tick Mark, Australia/NZ Emissions Compliant (M9210-xGx-3 and M9210-BDx Models)	
Shipping Weight	xGx Models	6.4 lb (2.9 kg)
	BAx and BDx Models	7.6 lb (3.5 kg)

The performance specifications are nominal and conform to acceptable industry standards. For application at conditions beyond these specifications, consult the local Johnson Controls office. Johnson Controls, Inc. shall not be liable for damages resulting from misapplication or misuse of its products.



Building Efficiency
507 E. Michigan Street, Milwaukee, WI 53202

Metasys® and Johnson Controls® are registered trademarks of Johnson Controls, Inc. All other marks herein are the marks of their respective owners. © 2009 Johnson Controls, Inc.