



TAC
1354 Clifford Avenue
P. O. Box 2940
Loves Park, IL 61132-2940
www.tac.com

AL-150 Series

Solenoid Air Valve General Instructions

Application

For applications where an electrical circuit is used to control a pneumatically operated device. Used to direct supply air to a pneumatic device when the coil is energized or de-energized depending on the supply and exhaust air connects.



Features

- Brass body provides long life.
- High capacity of AL-150 series allows more devices to be used with fewer solenoid air valves.
- All popular voltages from 24V to 480V available for maximum application flexibility.

Applicable Literature

- TAC Cross-Reference Guide, F-23638
- TAC Reference Manual , F-21683
- TAC Application Manual, F-21335
- EN-123 Air Quality Requirements for Pneumatic HVAC Control Systems F-22516

SPECIFICATIONS

Valve Inputs

Power Input: 6.1 Watts (energized).

Available Voltages: See Table-1.

Electrical Connections: 18" (457 mm) leads on the coil. Threaded hole for 1/2" conduit.

Maximum Inlet Air Pressure: 40 psig (276 kPa). Clean, dry, oil free air is required (reference EN-123).

Air Connections: 1/8" NPT.

N.C.: Normally closed, Port 2.

N.O.: Normally open, Port 3.

COM, Common, Port 1.

Valve Outputs

Flow Capacity: 1.15 scfm (580 ml/sec) @ 15 psig (138 kPa) supply with 1 psig (6.9 kPa) drop.

Environment

Ambient Temperature Limits:

Shipping, -40 to 150°F (-40 to 65°C).

Operating, 32 to 125°F (0 to 52°C).

Supply Air, 40 to 130°F (4 to 54°C).

Humidity: 5 to 95% RH, non-condensing.

Location: NEMA Types 1, 2, 3, 3S, 4, and 4X .

Table-1 Model Chart and Replacement Parts For Solenoid Air Valves.

Solenoid	Voltage (AC 60 Hz)	Replacement Part Number
AL-150	24	PNR-326-24
AL-151	120	PNR-326-120
AL-152	208	PNR-326-208
AL-153	240	PNR-326-240
AL-155	480	PNR-326-480

TYPICAL APPLICATION

When the supply fan is started, Electric Pneumatic (EP) Solenoid Air Valve E.P.-1 is energized, connecting N.C. and common ports. Main Air (20 Psig) is supplied to P.E.-1, starting Humidifier Fan; to Room Humidistat H-1, placing normally-closed Steam Humidifier Valve under control; to positioners of outside, Return and Relief Damper temperature controller, and to Remote Exhaust Damper Motor M-4, opening the normally-closed Exhaust Damper fully.

When the supply fan is stopped, E.P.-1 is de-energized, connecting the Common and N.O. ports, exhausting main air from control devices. P.E.-1 stops the Humidifier Fan; the normally-closed Humidifier Valve closes; the Outside Air and Relief Damper close; the Return Damper opens and the Exhaust Damper closes.

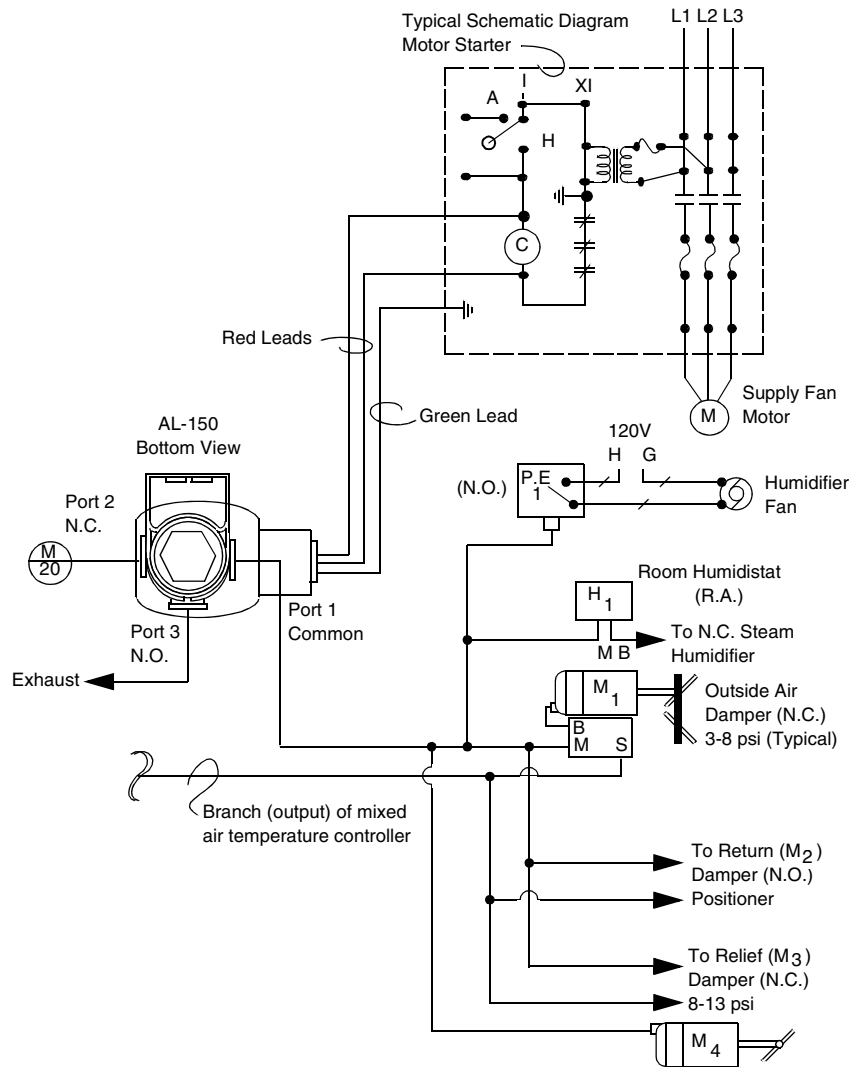

Figure-1 Typical Application Wiring Diagram.

INSTALLATION

Inspection

Inspect the carton for damage. If damaged, notify the appropriate carrier immediately. Inspect the device for obvious damage. Return damaged products.

Requirements

- Job wiring diagrams
- Tools (not provided)
- Training: Installer must be a qualified, experienced technician

▼CAUTION

- Disconnect the power supply (line power) before installation to prevent equipment damage.
- Make all connections in accordance with the wiring diagram and in accordance with national and local electrical codes. *Use copper conductors only.*
- Do not exceed ratings of the device(s).
- Avoid locations where excessive moisture, corrosive fumes, or vibration is present.

Mounting

Remote Mounting

NOTE

This method requires the use of the enclosure on the coil. An integral mounting plate is provided.

1. Fasten to wall or duct with two #8 sheet metal screws or equivalent.
2. Rotate the solenoid enclosure to position the wiring compartment, if necessary.

Inside Cabinet Mounting

1. Fasten to subpanel of cabinet with two #8 sheet metal screws.
2. Remove red cap.
3. Remove name plate by sliding out of coil.
4. Remove coil.
5. Install plunger tube through hole in electrical enclosure.
6. Re-install coil and coil hold down name plate snap red cap back on solenoid.

CAUTION

Do not over-tighten as this may cause distortion of plunger tube or damage coil.

CHECKOUT

Go No Go Test

1. Connect solenoid ports.
2. Apply air to Port #1, Ports #1 and #3 should be connected.
3. Apply power to the solenoid, Ports #1 and #2 should be connected.
4. If Ports #1 and #2 are not connected, check to see if the proper voltage is applied.
5. Replace the solenoid with a functional unit if solenoid is powered and Ports #1 and #2 are not connected.

MAINTENANCE

Regular maintenance of the total system is recommended to assure sustained optimum performance.

FIELD REPAIR

None. Replace with a functional solenoid.

DIMENSIONAL DATA

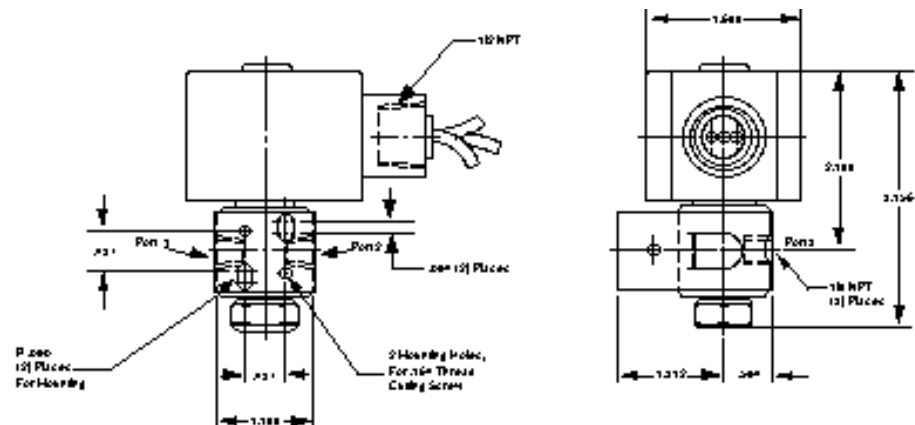

Figure-2 AL-150 Dimensional Drawing.

Copyright 2006, TAC
All brand names, trademarks and registered trademarks are the property of their respective owners. Information contained within this document is subject to change without notice.

TAC
1354 Clifford Avenue
P.O. Box 2940
Loves Park, IL 61132-2940

F-24752-1