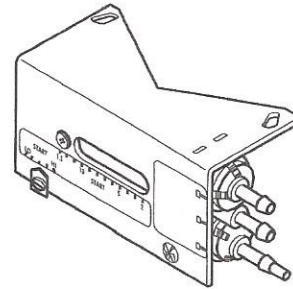

**Positive Positioner Pneumatic Relay
General Instructions****Application**

The AK-42309-500 Positive Positioner Pneumatic Relay is used to accurately position an actuator with respect to signal pressure from the controller. It can also be used to change the effective spring range of an actuator and increase the capacity of a controller.

The AK-42309-500 Positive Positioner Pneumatic Relay is compatible with MK-2690-0-0-1, MK-2690-0-0-2, MK-3XXX, MK-44XX, MK-46X1-XXX-0-2, MK-48XX, MK-66XX, MK-68XX, MK-69XX, MK-7XXX, MK-88XX, and MK-89XX Series actuators. The AK-42309-500 cannot be used with the following actuators: M556, M573, M574, M693, MK-2690-0-0-0, MK-4600-0-0-0, MK-4600-0-0-1, and MK-12000 Series actuators.

**Features**

- Force-balance relay-type position sensing mechanism
- Main-air and exhaust connections at actuator location speeds actuator response
- Large air capacity
- Adjustable start-point and span

Applicable Literature

- Environmental Controls Reference Manual, F-21683
- EN-123 Air Quality Requirements for Pneumatic HVAC Control Systems, F-22516
- Pneumatic Products Catalog, F-27383
- Material Safety Data Sheet, MSDS-7

SPECIFICATIONS

Action: Direct (increase in output pressure to actuator with an increase in pilot pressure from controller).

Pilot input: 0 to main air pressure, psig.

Output: 0 to main air pressure, psig.

Construction:

Housing, Polysulfone.

Diaphragm, Neoprene.

Start Point: Adjustable 1 to 12 psig (7 to 83 kPa).

Span: Adjustable 2 to 13 psig (14 to 90 kPa); factory set at 5 psig.

Supply Air: Clean, oil free, dry air required (refer to EN-123, F-22516).

Maximum Pressure, 30 psig (207 kPa).

Nominal Supply Pressure, 15 to 20 psig (103 to 138 kPa).

Environment:

Ambient Temperature Limits,

Shipping: -40 to 160°F (-40 to 71°C).

Operating: 32 to 140°F (0 to 60°C).

Humidity, 5 to 95% R.H., non-condensing.

Locations, NEMA Type 1.

Air Connection Code: See Figure-1.

Air connections:

"M" and "B," Barbed for 1/4 in. (6 mm) O.D. plastic tubing.

"P," Dual-contoured for 1/4 in. (6 mm) O.D. and 5/32 in. 4 mm) O.D. tubing.

Air Consumption for Sizing Air Compressor: 0.011 scfm (5.2 ml/s) at 20 psig (138 kPa) supply.

Air Capacity for Sizing Air Mains: 20 scim (5.5ml/s).

Flow Capacity: 860 scim (235 ml/s) at 20 psig (138 kPa) supply.

Mounting Linkage: All necessary linkage provided to mount the AK-42309-500 Positive Positioner to MK-2690-0-0-1, MK-2690-0-0-2, MK-3XXX, MK-44XX, MK-46X1-XXX-0-2, MK-48XX, MK-66XX, MK-68XX, MK-69XX, MK-7XXX, MK-88XX, and MK-89XX series actuators.

Dimensions: 2-1/2 H x 4-1/2 W x 3 D in. (64 x 114 x 76 mm). See Figure-12.

ACCESSORIES

TOOL-95-1 Pneumatic calibration tool kit.

TYPICAL APPLICATIONS (piping diagram)

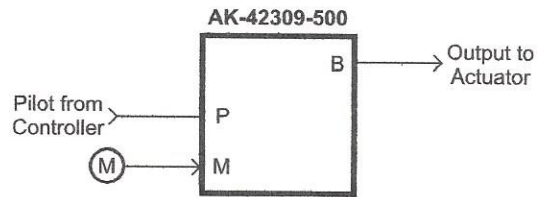

Figure-1 Piping Connections.

INSTALLATION

Inspection

Inspect the package for damage. If damaged, notify the appropriate carrier immediately. If undamaged, open the package and inspect the device for obvious damage. Return damaged products.

Requirements

- Piping diagrams
- Linkage kit (provided with the AK-42309-500 Positive Positioner)
- Tools (not provided):
 - 1/4" (6 mm) maximum single blade screwdriver for start point lock and span adjustment lock
 - Appropriate socket wrenches for mounting bracket to the actuator.
 - Needle nose pliers for bending feedback spring
 - Tubings and fittings (not provided)
- Training: Installer must be a qualified, experienced technician.

Precautions

General

Caution:

- Make all connections in accordance with the piping diagram.
 - Do not exceed the ratings of the device(s).
-

Main Air Supply

Caution:

- Particles in the main air supply larger than 0.03 microns will adversely affect the reliability and life of the relay unit. A refrigerated air dryer, particulate filter, and coalescing filter will provide a quality air supply (refer to EN-123, F-22516).
 - Oil, dirt, and water in the main air supply will cause unwarranted damage to the positive positioner and void the warranty.
 - Compressor oil must be mineral base. Synthetic base oils will destroy pneumatic controls and void the warranty.
-

Location

Caution: Do not locate unit in areas subject to excessive vibration or corrosive atmospheres.

Mounting

Suggested Mounting Sequence

- MK-2690-0-0-1, MK-2690-0-0-2, MK-46X1-XXX-0-2, and MK-48XX actuators can be mounted to the valve before the AK-42309-500 Positive Positioner is mounted to the actuator.
- The MK-66XX, MK-68XX, MK-69XX, MK-88XX, and MK-89XX series actuators can be mounted to the valve before the AK-42309-500 Positive Positioner is mounted to the actuator, but the valve linkage must be disconnected in order to install the feedback arm and the indication disc.
- When mounting the AK-42309-500 Positive Positioner to the MK-3XXX and MK-7XXX series actuators, mount the positive positioner to the actuator and install the positive positioner's feedback arm on the actuator before mounting the actuator to the damper.

Mounting the AK-42309-500 Positive Positioner to Actuators

MK-2690-0-0-1 and MK-2690-0-0-2 (Figure-2)

Mount the AK-42309-500 to the MK-2690-0-0-(1, 2) actuator as follows:

1. Line up positive positioner mounting bracket holes with the mounting holes on the actuator cover (Figure-2).
2. Assemble with the two (2) short mounting screws and tighten.
3. Select the appropriate spring and feedback arm from the linkage kit (Table-1). Balance of parts may be discarded or retained for spares.

MK-3XXX, MK-44XX, MK-46X1-XXX-0-2, and MK-48XX (Figure-3, Figure-4, and Figure-6)

Mount the AK-42309-500 to the MK-3XXX, MK-44XX, MK-46X1-XXX-0-2, and MK-48XX actuators as follows:

1. Remove referenced cover screws and discard.

Note: All older MK-3XXX actuators which do not have flat pads around mounting screw locations require spacers from the linkage kit provided with the AK-42309-500 Positive Positioner.

2. Line up positive positioner mounting bracket holes with actuator cover screw holes shown in Figure-3, Figure-4, and Figure-6.
3. Reassemble with specified screws (included with the AK-42309-500) through positive positioner mounting bracket holes and tighten.
4. Select the appropriate spring and feedback arm from the linkage kit (Table-1). Balance of parts may be discarded or retained for spares.

MK66XX, MK-68XX, MK-69XX, MK-7XXX, MK-88XX, and MK-89XX (Figure-7, Figure-8, and Figure-9)

Mount the AK-42309-500 to the MK-66XX, MK-68XX, MK-69XX, MK-7XXX, MK-88XX, and MK-89XX series actuators as follows:

1. Remove actuator cover screws and set aside.
2. Line up positive positioner mounting bracket holes with actuator cover screw holes. (See Figure-7, Figure-8, or Figure-9.)
3. Reassemble with actuator cover screws through positive positioner mounting bracket holes and tighten.
4. Select the appropriate spring and feedback arm from the linkage kit provided with the AK-42309-500 Positive Positioner (Table-1). Balance of parts from the linkage kit may be discarded or retained for spares.

Installing the Feedback Arm

MK-2690-0-0-1, MK-2690-0-0-2, MK-44XX, MK-46X1-XXX-0-2, and MK-48XX (Figure-2, Figure-5, and Figure-6)

Install the feedback arm on the AK-42309-500 Positive Positioner as follows:

1. Consult Table-1 to select appropriate feedback arm.
2. Push the feedback arm firmly into the hole provided in the diaphragm piston with the hook rotated 45° to 90° from the final position.
3. Lock the arm into the diaphragm piston by twisting the arm into position with a downward force.

MK-3XXX, MK-66XX, MK-68XX, MK-69XX, MK-7XXX, MK-88XX, and MK-89XX (Figure-3, Figure-7, Figure-8, and Figure-9)

To install, secure the feedback arm to the valve stem or actuator output shaft.

Installing the Feedback Spring







Install the feedback spring as follows:

1. Choose the appropriate feedback spring from the linkage kit provided with the AK-42309-500 Positive Positioner.
2. Move the AK-42309-500 Start Point lever (Figure-10) to the "Lo" position (required to position the feedback lever).
3. Position the span adjustment slider to align the spring hook mounting hole to the scale below (required to set the operating span of the actuator).
4. Line up the feedback arm and span adjustment slider.
5. Insert hooked end of feedback spring into the back of the hole on the span adjustment slider (Figure-10).
6. Cut off feedback spring 1/2 to 3/4" (13 to 19 mm) beyond the end of the feedback arm.
7. Form bend, approximately 1/4" (6 mm) from the free end of the feedback spring to allow approximately 1/32 to 1/16" (0.8 to 1.6 mm) tension at the feedback arm.

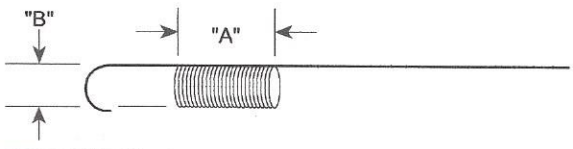
Caution: Do not put a sharp bend in the feedback spring. More than 1/16" (1.6 mm) of tension on the spring may prevent adjustment to low start points.

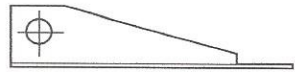
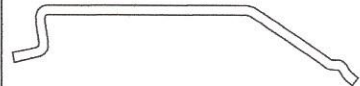
8. Connect the bent end of the feedback spring to the feedback arm.

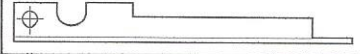
Table-1 Actuator and Valve Compatibility with AK-42309-500 Positive Positioner Feedback Arm.

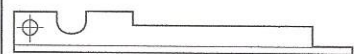
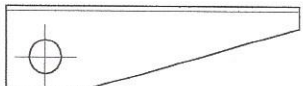
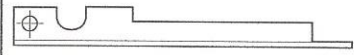
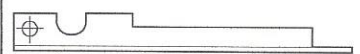
Feedback Spring Dimensions						
						
Actuator	Where Used, valve size in inches (metric equivalent in mm)	Factory Set Actuator Stroke in. (mm)	Dimension "A" in. (mm)	Dimension "B" in. (mm)	Feedback Arm	Feedback Arm Mounting Hole Diameter in. (mm)
MK-2690-0-0-1 and MK-2690-0-0-2 ^a	VB-7XXX and VB-9XXX, 1/2 to 1-1/4 (15 to 50)	7/16 (11)	11/16 (17)	5/16 (8)		N.A.
MK-3XXX	Dampers	3-1/2 (89) Adjustable 2 to 4 (51 to 102)	For actuator strokes less than 3 (76) ^b , 1-1/8 (29). For strokes 3 to 4 ^b (76 to 102), 1-5/8 (41).	11/16 (17)		21/64 (8)
MK-44XX	Dampers	1 ^c (25)	1-3/32 (28)	7/16 (11)		N.A.
MK-46X1-XXX-0-2 ^a	VB-7XXX, 1/2 to 2 (15 to 50) and VB-9XXX, 1/2 to 1-1/4 (15 to 32)	7/16 (11)	11/16 (17)	5/16 (8)		N.A.
MK-48XX ^d	VB-9XXX, 1-1/2 to 2 (40 to 50)	29/32 (23)	1-3/32 (28)	7/16 (11)		N.A.
MK-66XX	VB-7XXX, 1/2 to 2 (15 to 50)	7/16 (11)	11/16 (17)	5/16 (8)		N.A.
MK-68XX	VB-9XXX, 1-1/2 to 4 (40 to 80)	29/32 (23)	1-3/32 (28)	7/16 (11)		N.A.
MK-69XX	VB-9XXX, 5 and 6 (none)	1-27/32 (46)	1-1/8 (29)	11/16 (17)		N.A.
MK-7XXX	Dampers	4-1/2 (114) Adjustable 4 to 5 (102 to 127)	2-1/4 (57) ^b	11/16 (17)		33/64 (13)
MK-88XX	VB-9XXX, 2-1/2 to 4 (65 to 80)	29/32 (23)	1-3/32 (28)	7/16 (11)		N.A.
MK-89XX	VB-9XXX, 5 and 6 (none)	1-27/32 (46)	1-1/8 (29)	11/16 (17)		N.A.

^a AK-42309-500 cannot be mounted on MK-2690-0-0-0, MK-4600-0-0-(0,1), or MK-12000 series actuators.

^b See page 10 for Span Slider Setting Instructions.

^c Linkage is factory set at 2" (51mm). Linkage is adjustable from 1/2 to 3" (13 to 76mm).

^d The MK-48XX actuator series is offered for retrofit on obsolete VB-9XXX valves. This actuator cannot be used with VB-7XXX valves.

Piping

Before installing tubing, see Figure-2 through Figure-9 for proper alignment and refer to the piping diagram and an example of typical piping (Figure-1 and Figure-11). Install tubing as follows:

1. Install 1/8 MNPT x 1/4" (3.2 x 6mm) barb fitting into air connection on actuator.

Note: Barb fitting provided with MK-8XXX only.

2. Connect 1/4" O.D. (6mm) plastic tubing between fitting in actuator and "B" port on the positive positioner.
3. Connect main air supply to "M" port.
4. Connect controller output (variable air signal) to "P" port.

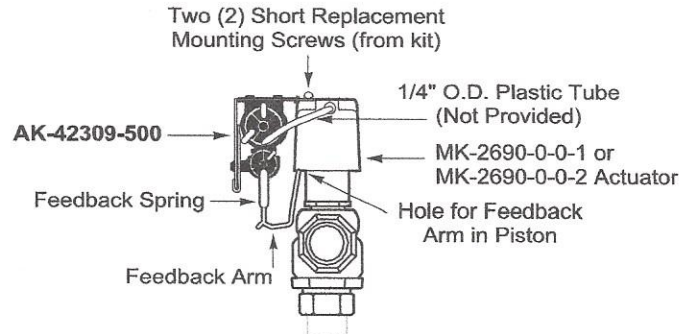

Figure-2 MK-2690-0-0-1 and MK-2690-0-0-2.

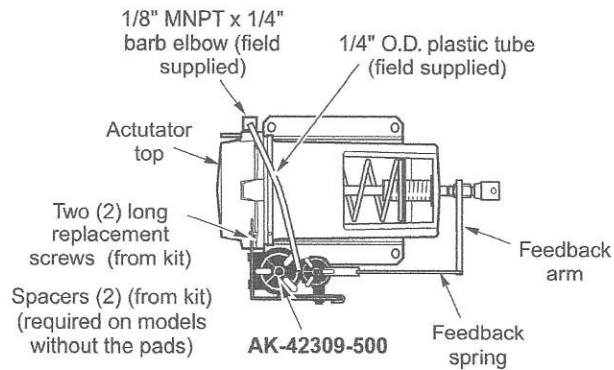

Figure-3 MK-3XXX

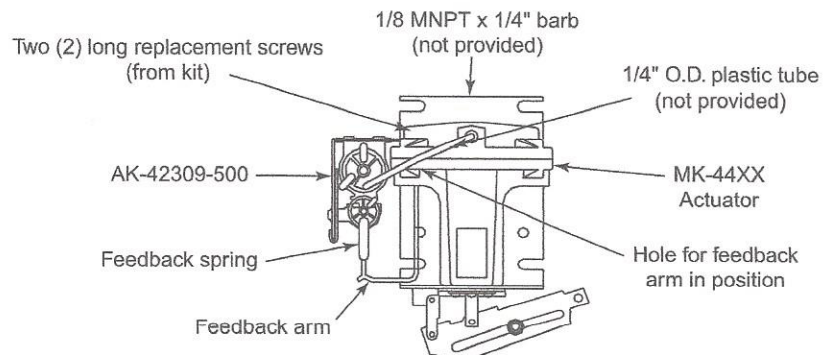

Figure-4 MK-44XX.

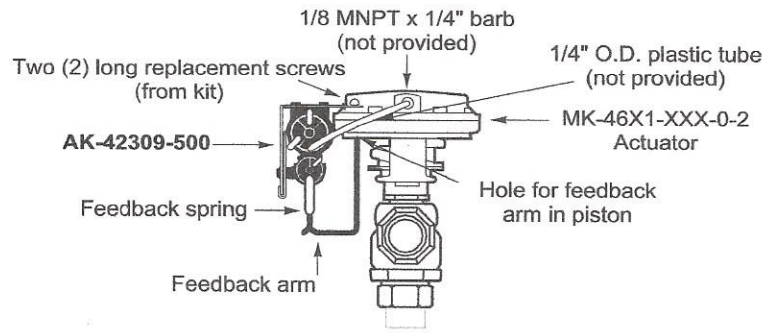

Figure-5 MK-46X1-XXX-0-2 Series.

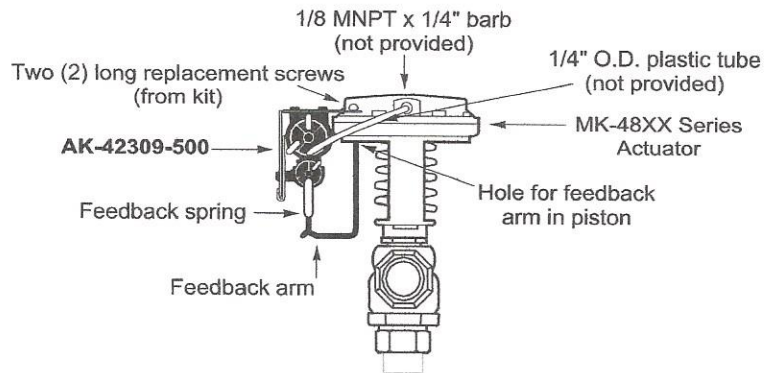

Figure-6 MK-48XX Series.

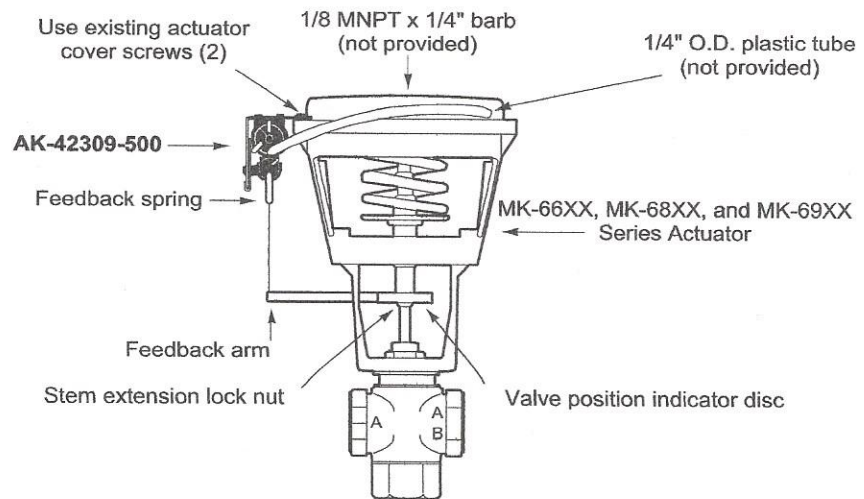

Figure-7 MK-66XX, MK-68XX, and MK-69XX Series

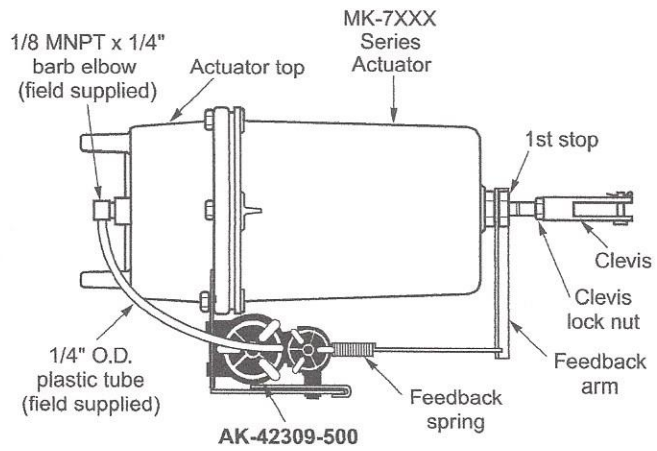

Figure-8 MK-7XXX Series.

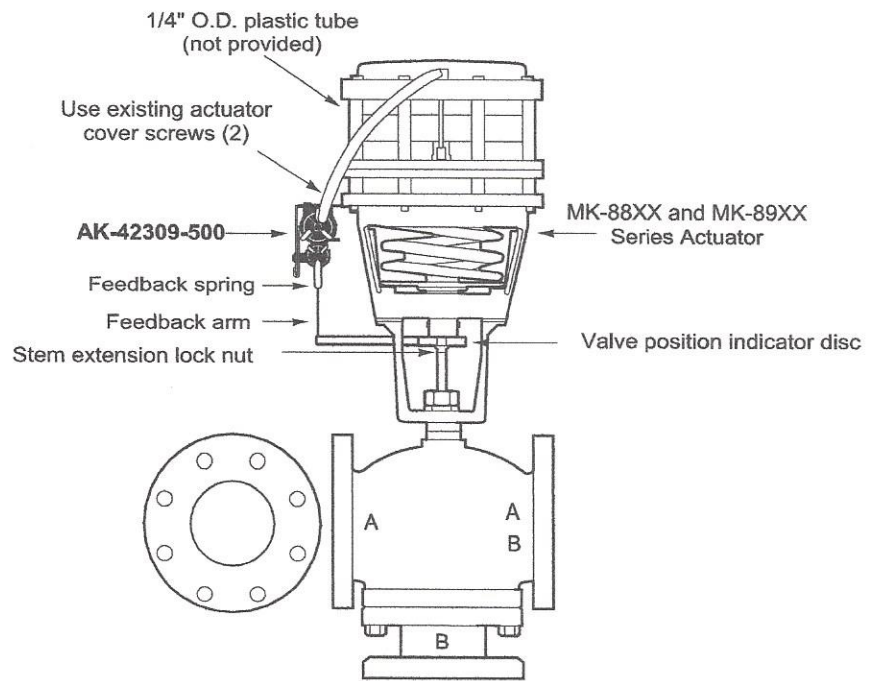

Figure-9 MK-88XX and MK-89XX Series.

Setup

Start Point (Figure-10 and Figure-11)

Start point is the pressure at which the actuator shaft just begins to extend. Start point must be adjusted after any span slider setting. Adjust the start point as follows:

1. Connect main air supply to "M" port and a variable air signal to "P" port.
2. Adjust variable air signal on "P" port to desired start point pressure.
3. Loosen start point lever lock screw.
4. Adjust lever until actuator just starts to extend.
5. Tighten lock screw.
6. Remove variable air signal from "P" port and connect to controller output.

Span Slider Setting (Figure-10 and Figure-11)

Span is the pilot pressure change required to produce a full actuator stroke. The span can be changed by repositioning the span adjustment slider.

MK-2690-0-0-1, MK-2690-0-0-2, MK-44XX, MK-46X1-XXX-0-2, MK-48XX, MK-66XX, MK-68XX, MK-69XX, MK-88XX, MK-89XX

1. Determine the span required.
2. Set the span adjustment slider.

MK-3XXX and MK-7XXX

The MK-3XXX and MK-7XXX series actuators have adjustable strokes. The adjustable stroke requires the span adjustment slider setting to be calculated for the AK-42309-500 Positive Positioner.

1. Determine the required actuator stroke.
2. Determine the span required.
3. Calculate the span adjustment slider position (SASP) as follows:
 - MK-3XXX with stroke less than 3" (76 mm)

$$\frac{\text{Span} \times 2}{\text{ActuatorStroke}} = \text{SASP}$$

- MK-3XXX with stroke 3 to 4" (76 to 102 mm)

$$\frac{\text{Span} \times 3}{\text{ActuatorStroke}} = \text{SASP}$$

- MK-7XXX

$$\frac{\text{Span} \times 4}{\text{ActuatorStroke}} = \text{SASP}$$

Example: MK-3XXX

Span = 8 psi (55 kPa)

Actuator Stroke = 3-1/2" (89 mm)

$$\text{SASP} = \frac{8 \times 3}{3.5} = 6.9$$

4. Set span adjustment slider to the calculated position.

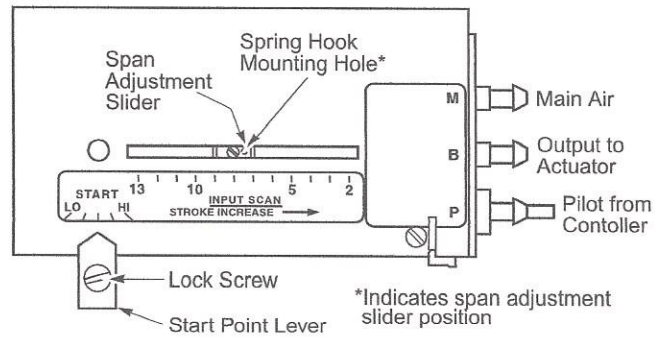

Figure-10 AK-42309-500 Adjustments.

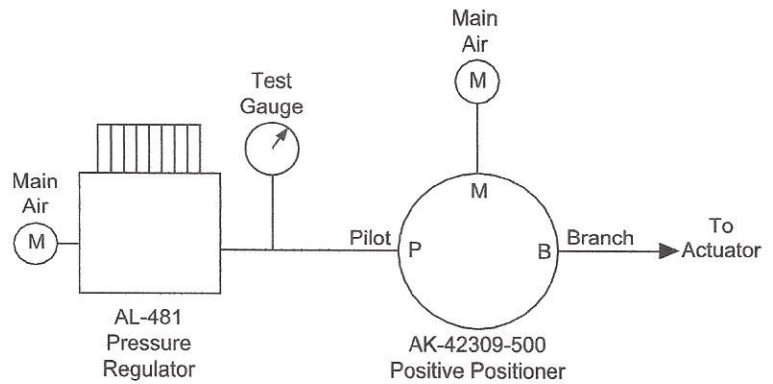

Figure-11 Typical Adjustment Piping.

MAINTENANCE

Regular maintenance of the total system is recommended to assure sustained optimum performance.

FIELD REPAIR

None. Replace an inoperative positive positioner with a functional unit.

DIMENSIONAL DATA

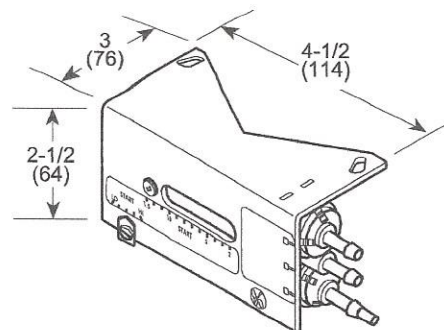

Figure-12 AK-42309-500 Dimensions.