

5004-795 FLAME SAFEGUARD CONTROLLER

Product Overview

Description

The **Quanta-Flame 5004-795** is a state-of-the-art flame safeguard controller series designed for on-off single burner process heat applications. The controller sequences the burner through Purge, Ignition, Pilot Trial for Ignition, Main Trial for Ignition, and Run modes. It monitors the burner flame and running interlocks to safely shut down the burner in the event of an unsafe operating condition.

- No re-wiring required when replacing an R4795 controller
- Operates with existing UV sensors and flame rods
- 5004-795A model automatically resets when power is restored after an interruption

The 5004-795 series controllers are a direct replacement for most Honeywell R4795 controls.

Controller Functions

The controller sequences the burner through Purge, Ignition, Pilot Trial for Ignition, Main Trial for Ignition, and Run modes. It monitors the burner flame and running interlocks to safely shut down the burner in the event of an unsafe operating condition. LEDs are provided for status and diagnostics including: Flame Proven, Limits Made, Combustion Air Present, Pilot Gas Valves Energized, Main Gas Valves Energized, Air Switch Fault, Flame Failure, Lockout, and Power.

Features Include

- Optional plug-in diagnostic display
- Microcomputer burner control
- DIP switch selectable purge time (30, 60, 150, 180, 300, 450) seconds
- Standard relay alarm contact
- Pilot test mode
- Selectable Trial for Ignition times (3, 5, 10, or 15) seconds
- Selectable Interrupted or Intermittent Pilot
- Selectable Recycle or Non-Recycle modes
- Every unit interfaces to ultraviolet or flame rod sensors
- Easy control panel mounting

Functional Summary

Recycle Mode

When selected, the control will recycle the burner through Purge and startup when the main burner has shutdown with a Flame Failure alarm. The recycling of the burner will only occur after the main burner has been in operation. There is no recycle on pilot flame failure.

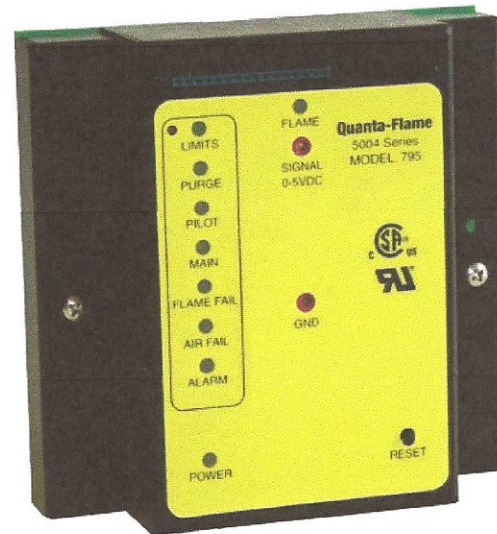

Quanta-Flame 5004-795 Flame Safeguard Controller

Pilot Turndown Test Mode

Permits the pilot to ignite and remain burning regardless if Interrupted or Intermittent pilot has been selected. The main burner will not be ignited as long as the control is in this mode. This permits the service technician to adjust and inspect the pilot flame. To enter this mode hold the reset button down until the limit light begins to flash (10 seconds). To exit the pilot test mode press the reset button and the control will reset into the normal run mode.

Interrupted Pilot

The pilot will ignite and be turned off 10 seconds after the main burner valve is opened.

Intermittent (non-interrupted pilot)

The pilot will ignite and remain lit for the entire duration of the main burner run cycle.

Pilot Verification Feature

The ignitor will be de-energized 5 seconds before the main valve is energized to ensure the pilot flame is stable before lighting the main burner.

False Flame Indication

If the control senses a flame out of the proper sequence, the sequence will stop and wait for 30 seconds for the False Flame signal to disappear. During this time the Flame Fail light and the Alarm light will blink on and off. If the signal disappears the lights will cease blinking and the sequence will continue. If the False Flame signal is present for more than 30 seconds the lights will stay on continuously and the control will go into lockout.

Flame Signal Analog Meter Jacks

Two test probe inputs are located on the front of the control. By inserting the meter probes from a high impedance (100k ohm/volt) DC volt meter the control will indicate the relative flame signal level in the range of 0 to 5 VDC.

Edgemont Precision Rebuilders, Inc
Matlack Industrial Center
207 Carter Dr Suite C
West Chester, PA 19382
800-356-3774

Preferred Manufacturing

5004-795 FLAME SAFEGUARD CONTROLLER

System Overview

Selectable Purge Time

The Purge time is selectable by means of the selector switches located under the right hand cover of the control. The Purge times selected by each switch (5 through 8) are added together for the total purge time. (For example, the maximum Purge time is 7 + 10 + 30 + 60 seconds or 107 seconds).

Shorted Air Switch Check

The control verifies that the air switch is not shorted at each occurrence of control lockout. When the fan is de-energized during lockout the control will check to see if the air switch opens. If the air switch fails to open the "air fail" light will blink to indicate the air switch is still closed. This will alert the operator that the air switch is not functioning properly.

Air Failure

The control constantly monitors the airflow switch input. The input must be present before the purge time will begin. If the control loses the air switch input at some point in the burner cycle after the start of Purge, the control will reset to the start of the Purge cycle and wait for the air switch to close.

Control Reset

When the control enters a Lockout condition the red Alarm light will light and begin blinking. To reset the control press the Reset button on the front of the control for three seconds. The control will not reset on power interruption. Lockout conditions for the control are:

- Flame failure
- False flame present for more that 30 seconds
- Relay failure and internal fault



5004-216RN Flush-Mount Remote Display

Remote Display

The optional 5004-216RN display is a panel mounted display for the 5004 Series Quanta-Flame Controls. It mounts in a control panel through a 1/8 DIN mounting hole and is secured with the included mounting clips.

During operation the display will indicate each step in the control sequence. When the main burner is in the run mode the flame signal level will be indicated in a range of 0 to 5 VDC.

The display constantly refreshes itself with new information from the control. This refreshing is indicated by the slight periodic blink of the messages.

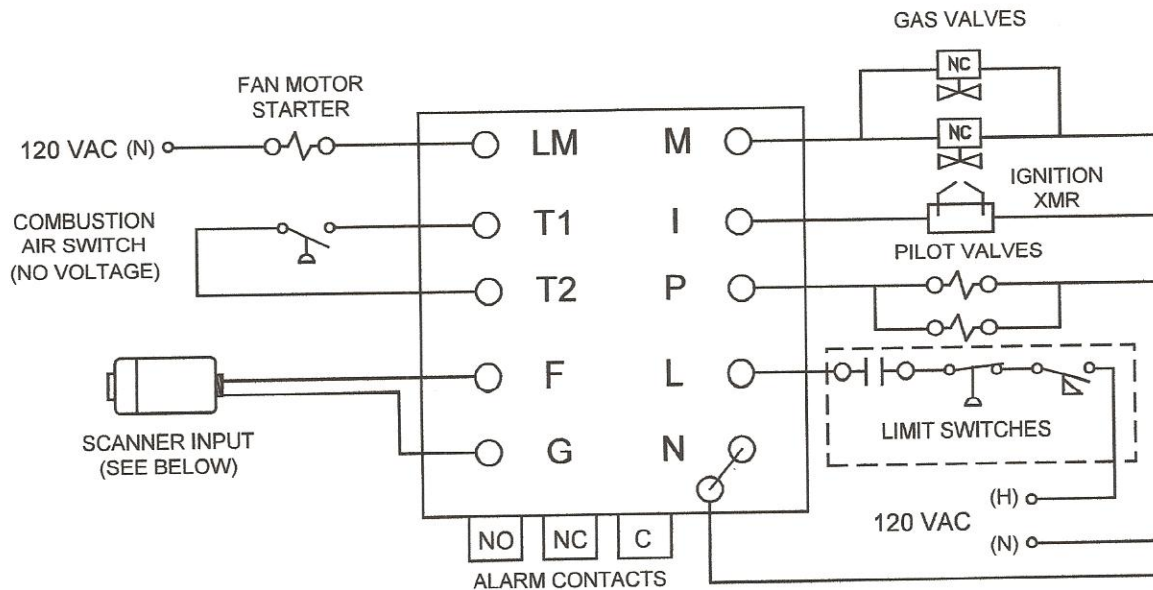

Typical 5004-795 Series Wiring Schematic.

Edgemont Precision Rebuilders, Inc
Matlack Industrial Center
207 Carter Dr Suite C
West Chester, PA 19382
800-356-3774

5004-795 FLAME SAFEGUARD CONTROLLER

System Overview

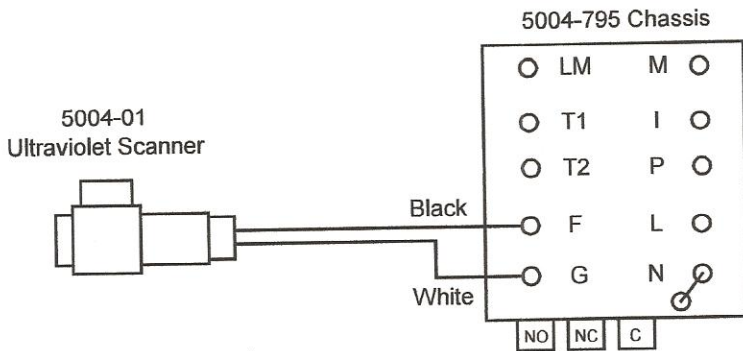

Scanner Wiring for 5004-01 Flame Scanners

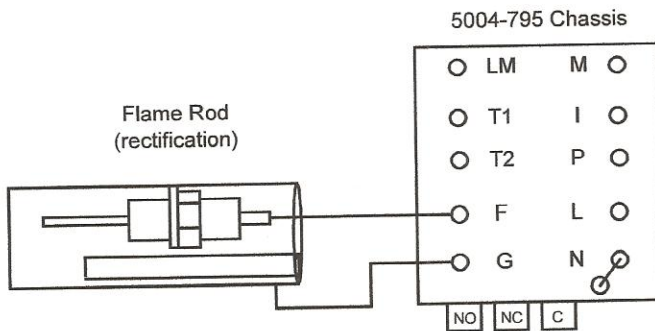

Flame Rod Wiring for 5004-795 Flame Safeguard Controller

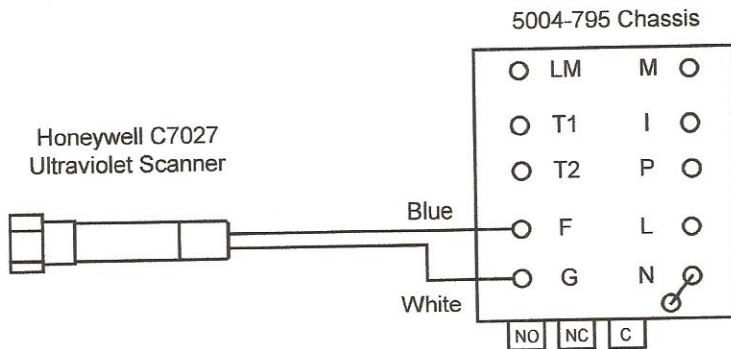

Scanner Wiring for Honeywell Flame Scanners

Controller Inputs:

Power (Terminal L)

Input that receives all the permissives and the burner start signal switch or contact

Neutral (Terminal N)

Grounded neutral connection to control.

Air Switch (Terminals T1 & T2)

Input is connected to the combustion airflow switch. This must be a dry contact. No voltage can be applied to these terminals. Voltage applied to these terminals will damage control and void the warranty

Flame Sensor (Terminals F & G)

Sensor inputs:

Flame rod connects to Terminal F

UV sensor connects to F & G. (see wiring schematics)

Outputs

Combustion Fan (Terminal LM)

Output to energize the burner combustion fan.

Pilot (Terminal P)

Output to energize the burner pilot valve.

Ignition (Terminal I)

Output to energize the ignition transformer.

Main (Terminal M)

Output to energize the burner main valve.

Alarm (NO, NC, C)

This is a dry contact output, which closes when an alarm condition occurs. (rated up to 230 VAC, 2 A max)

Product Certifications:

UL Recognized:

File No. E233069

CSA Certified:

Number 204571-1435343

Edgemont Precision Rebuilders, Inc
 Matlack Industrial Center
 207 Carter Dr Suite C
 West Chester, PA 19382
 800-356-3774

Google Maps
5004-795 FLAME SAFEGUARD CONTROLLER
 System Overview

Controller Specifications:

Mechanical

Enclosure: 5" H by 5" W by 1 3/4" D
Shipping Weight: 2 lbs. for all models
Area Classification: NEMA 1
Temperature Range: 0°F to +140°F (-40°C to +60°C)

Electrical

Voltage: 120 VAC 50/60Hz
Power Consumption: 2 VA
Load Ratings (pilot & main): 10 A (1/4 HP inductive)
Fan Output: 15 A (1/3 HP inductive)
Total Connected Load: 15 A (1800 VA)
Alarm Contact: 230 VAC, 2 A maximum

Optional Panel-Mounted Display

The optional 5004-216RN display is a panel-mounted display for the 5004 Series Quanta-Flame Controls. It mounts in a control panel through a 1/8 DIN mounting hole and is secured with the included mounting clips. During operation the display will indicate each step in the control sequence. When the main burner is in the Run mode the flame signal level will be indicated in a range of 0 to 5 VDC.

Ordering Information

Description	Catalog Number
5004-795 "Purge" Controller (Replaces HW R4795 Controllers)	
UV scanner or flame rod input. Purge and TFI time selectable	5004-795-0-0-00
UV scanner or flame rod input. Purge and TFI time selectable; Automatic Reset (w/new controller only)	5004-795-0-A-00
UV scanner or flame rod input. Purge and TFI time selectable; Historical Alarm Log (last 16 alarm events) Requires optional 5004-216 display	5004-795-0-0-LG
UV scanner or flame rod input. Purge and TFI time selectable; Automatic Reset (w/new controller only); Historical Alarm Log (last 16 alarm events) Requires optional 5004-216 display	5004-795-0-A-LG

Suggested Specification:

1. Microprocessor Flame Safeguard Controller

Controller shall be U.L. recognized and CSA certified for single burner boiler applications. The controller shall be a plug-in replacement for Honeywell R4795 controllers. The controller shall be capable of accepting inputs from ultraviolet, self-checking ultraviolet, and flame rod detectors without changing controller hardware. Pilot Trial for Ignition (PTFI) timing, and other control functions shall be DIP switch selectable.

2. Flame Safeguard Controller Hardware

Controller and included flame amplifier circuitry shall be microprocessor-based and include the following as a minimum:

- Removable LCD display for status information and troubleshooting information.
- Optional remote display

Edgemont Precision Rebuilders, Inc
 Matlack Industrial Center
 207 Carter Dr Suite C
 West Chester, PA 19382
 800-356-3774

The display constantly refreshes itself with new information from the control. This refreshing is indicated by the slight periodic blink of the messages.

During the Trial for Ignition period the display may show a blank line across the top row. This indicates the presence of an electrical noise field generated by the ignition circuit. This in no way affects the display or the control. The display will revert to the proper message when the electrical noise ends.

Display Specifications:

Mechanical

Enclosure: 1 3/4" H by 3 1/2" L by 3" D (1/8th DIN)
Area Classification: NEMA Type 4 Membrane Front
Electrical Supply: 120 VAC 50/60 Hz
Power consumption: 2 VA
Output: Relay reset contact (15 A), communication cable to 5004 control
Environmental: Temperature: 0° F to 140° F (-20° C to +60° C).

- Sequence status LEDs on the controller faceplate including: Purge (green) Limits Made(green), Pilot (yellow), Main (yellow), Air Fail (red), Flame Fail (red), Alarm (red) Power (red), Flame (red),
- Test jacks for direct flame intensity measurement (0-5 VDC)

3. Flame Safeguard Functions

The controller shall cycle the burner from Standby, through Purge, supervised Pilot Trial for Ignition, Main Flame Trial for Ignition and Run modes. De-energization of Pre-Ignition Interlocks, Running Interlocks, or loss of flame signal shall result in the safe shutdown of the burner.

4. Manufacturer

The flame safeguard controller shall be model 5004-795-0-xx manufactured by Preferred Utilities Mfg. of Danbury, CT.

